

# HDMI™ 70M HDBaseT Extender



**User Manual**

**VER 2.0**

## Thank you for purchasing this product

For optimum performance and safety, please read these instructions carefully before connecting, operating or adjusting this product. Please keep this manual for future reference.

## Surge protection device recommended

This product contains sensitive electrical components that may be damaged by electrical spikes, surges, electric shock, lightning strikes, etc. Use of surge protection systems is highly recommended in order to protect and extend the life of your equipment.

## Table of Contents

1. Introduction.....	1
2. Features.....	1
3. Package Contents.....	1
4. Specifications.....	2
5. Operation Controls and Functions.....	3
5.1. Transmitter Panel.....	3
5.2. Receiver Panel.....	4
6. Application Example.....	6

## 1. Introduction

This HDMI 70M HDBaseT Extender uses HDBaseT technology to extend the HDMI signal and bi-directional IR control signal to 70m via a single Cat5e/6 cable.

This product converts the HDMI signal into a standard HDBaseT signal and then transmits it through the LAN cable. It can easily control the signal source device or display device from the remote end via bi-directional IR signal pass-through. It supports RS-232 signal pass-through, and the resolution is up to 4K2K@30Hz.

This product can be widely used in video conference system, multimedia broadcasting, HDMI signal extension and other fields.

## 2. Features

- ☆ HDCP 2.2 compliant
- ☆ Support video resolution up to 4K2K@30Hz, as specified in HDMI 1.4
- ☆ Support 10.2Gbps video bandwidth
- ☆ The maximum transmission distance via a single CAT5e/6 cable is:  
70 meters: 1080P@60Hz/36bit; 3D 1080P@30Hz/36bit;  
40 meters: 1080P@60Hz/48bit; 1080P@120Hz/24bit;  
3D 1080P@60Hz/36bit; 4K2K@30Hz/24bit.
- ☆ Support POC (Power Over Cable) function, it means that either the transmitter or receiver is connected to 12V/1A power supply, the other doesn't need power supply.
- ☆ With bi-directional IR and RS-232 control signal pass-through
- ☆ Compact design for easy and flexible installation

## 3. Package Contents

- ① 1× HDMI 70M HDBaseT Extender (Transmitter)
- ② 1× HDMI 70M HDBaseT Extender (Receiver)
- ③ 1× Power Adaptor (12V DC,1A)
- ④ 1× IR Receiver Cable (1.5 meters)
- ⑤ 1× IR Blaster Cable (1.5 meters)
- ⑥ 4× Mounting Ears
- ⑦ 2× 3-pin Phoenix Connectors
- ⑧ 1× User Manual

## 4. Specifications

Technical	
HDMI Compliance	HDMI 1.4
HDCP Compliance	HDCP 2.2
Bandwidth	10.2Gbps
Video Resolutions	Up to 4K2K@30Hz 4:4:4
Transmission Mode	HDBaseT
Transmission Distance	1080P≤70m; 4K×2K≤40m
ESD Protection	IEC 61000-4-2: ±8kV (Air-gap discharge) , ±4kV (Contact discharge)
Connection	
Transmitter ports	Input: 1× In [HDMI Type A, 19-pin female] Output: 1× HDBaseT Out [RJ45] Control: 1× IR In [3.5mm stereo mini-jack] 1× IR Out [3.5mm stereo mini-jack] 1× RS-232 [phoenix connector]
Receiver ports	Input: 1× HDBaseT In [RJ45] Output: 1× Out [HDMI Type A, 19-pin female] Control: 1× IR In [3.5mm stereo mini-jack] 1× IR Out [3.5mm stereo mini-jack] 1× RS-232 [phoenix connector]
Mechanical	
Housing	Metal Enclosure
Color	Black
Dimensions	Transmitter/Receiver: 120mm (W)×74mm (D)×16mm (H)
Weight	Transmitter/Receiver: 240g
Power Supply	Input: AC100~240V 50/60Hz Output: DC12V/1A (US/EU standards, CE/FCC/UL certified)
Power Consumption	10W (Max)
Operating Temperature	0°C ~ 40°C / 32°F ~ 104°F
Storage Temperature	-20°C ~ 60°C / -4°F ~ 140°F
Relative Humidity	20~90% RH (non-condensing)

# 5. Operation Controls and Functions

## 5.1 Transmitter Panel

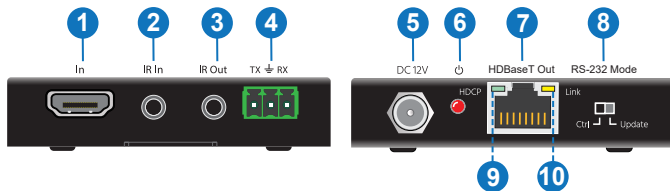

No.	Name	Function Description
1	In	HDMI signal input port. Connect HDMI source device.
2	IR In	Work with far-end IR Out port, connect with 12V IR Receiver to collect IR signal to control far-end display device from local.
3	IR Out	Work with far-end IR In port, connect with 12V IR Blaster to send IR signal to control input source device from remote.
4	RS-232 connector	Connect to control system or PC with 3-pin phoenix connector for RS-232 command transmission.
5	DC 12V	DC 12V power supply port. Support bi-directional POC function.
6	Power LED	Red LED will be on when the Transmitter is powered on.
7	HDBaseT Out	Connect to the HDBaseT In port of the Receiver via a CAT5e/6 cable.
8	RS-232 Mode switch	Ctrl — RS-232 pass-through control mode. Update — Update mode (connect the RS-232 port to a PC to update the Valens IC program.)
9	Data Signal Indicator (Green)	<ul style="list-style-type: none"><li>• Illuminate: HDMI signal with HDCP.</li><li>• Flash: HDMI signal without HDCP.</li><li>• Dark: No HDMI signal.</li></ul>
10	Connection Signal Indicator (Yellow)	<ul style="list-style-type: none"><li>• Illuminate: Transmitter and Receiver are in good connection status.</li><li>• Flash: Transmitter and Receiver are in poor connection status.</li><li>• Dark: Transmitter and Receiver are not connected.</li></ul>

## 5.2 Receiver Panel

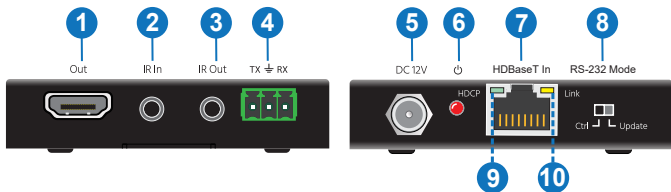

No.	Name	Function Description
1	Out	HDMI signal output port. Connect HDMI display device.
2	IR In	Work with far-end IR Out port, connect with 12V IR Receiver to collect IR signal to control far-end display device from local.
3	IR Out	Work with far-end IR In port, connect with 12V IR Blaster to send IR signal to control input source device from remote.
4	RS-232 connector	Connect to control system or PC with 3-pin phoenix connector for RS-232 command transmission.
5	DC 12V	DC 12V power supply port. Support bi-directional POC function.
6	Power LED	Red LED will be on when the Receiver is powered on.
7	HDBaseT In	Connect to the HDBaseT Out port of the Transmitter via a CAT5e/6 cable.
8	RS-232 Mode switch	Ctrl — RS-232 pass-through control mode. Update — Update mode (connect the RS-232 port to a PC to update the Valens IC program.)
9	Data Signal Indicator lamp (Green)	<ul style="list-style-type: none"> <li>• Illuminate: HDMI signal with HDCP.</li> <li>• Flash: HDMI signal without HDCP.</li> <li>• Dark: No HDMI signal.</li> </ul>
10	Connection Signal Indicator lamp (Yellow)	<ul style="list-style-type: none"> <li>• Illuminate: Transmitter and Receiver are in good connection status.</li> <li>• Flash: Transmitter and Receiver are in poor connection status.</li> <li>• Dark: Transmitter and Receiver are not connected.</li> </ul>

### ※ Description 1

#### POC(Power Over Cable) Application Example

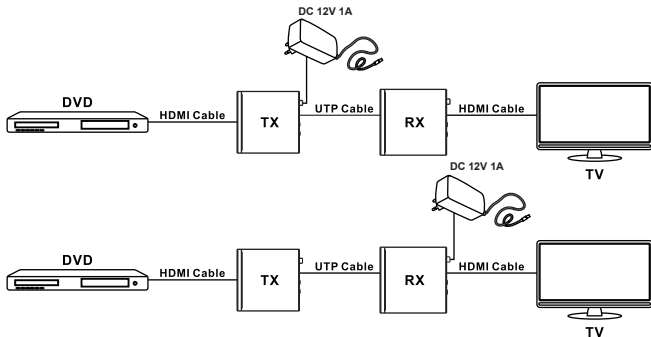

### ※ Description 2

#### Bidirectional Infrared control Application Example

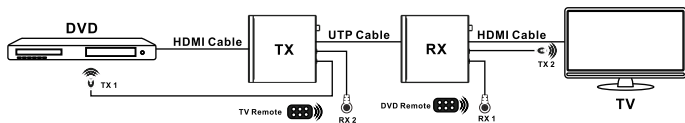

### ※ Description 3

#### Bidirectional RS-232 control Application Example

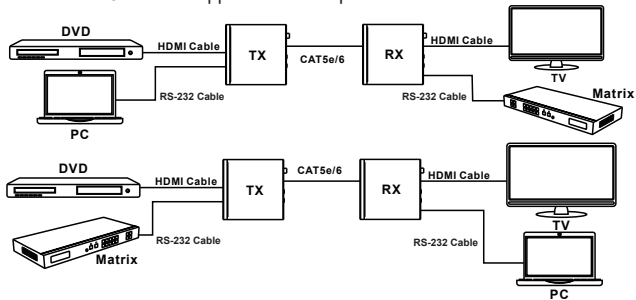

## 6. Application Example

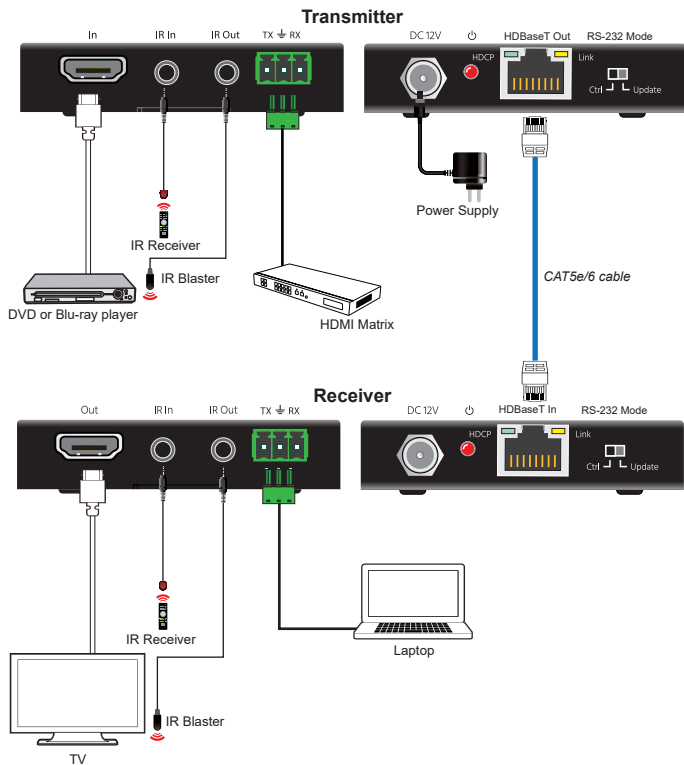

**HDMI**™  
HIGH-DEFINITION MULTIMEDIA INTERFACE

The terms HDMI and HDMI High-Definition Multimedia interface, and the HDMI Logo are trademarks or registered trademarks of HDMI Licensing LLC in the United States and other countries.