

User Manual

WOXCON

MUH88T-H2 KIT

**8x8 HDMI 2.0 HDBaseT Matrix Switcher with
8 Receivers**



All Rights Reserved

Version: MUH88T-H2 KIT_2019V1.3

8x8 HDMI 2.0 HDBaseT Matrix Switcher

Preface

Read this user manual carefully before using the product. Pictures shown in this manual are for reference only. Different models and specifications are subject to real product.

This manual is only for operation instruction, please contact the local distributor for maintenance assistance. The functions described in this version were updated till November, 2019. In the constant effort to improve the product, we reserve the right to make functions or parameters changes without notice or obligation. Please refer to the dealers for the latest details.

FCC Statement

This equipment generates, uses and can radiate radio frequency energy and, if not installed and used in accordance with the instructions, may cause harmful interference to radio communications. It has been tested and found to comply with the limits for a Class B digital device, pursuant to part 15 of the FCC Rules. These limits are designed to provide reasonable protection against harmful interference in a commercial installation.

Operation of this equipment in a residential area is likely to cause interference, in which case the user at their own expense will be required to take whatever measures may be necessary to correct the interference.

Any changes or modifications not expressly approved by the manufacture would void the user's authority to operate the equipment.



8x8 HDMI 2.0 HDBaseT Matrix Switcher

SAFETY PRECAUTIONS

To ensure the best performance from the product, please read all instructions carefully before using the device. Save this manual for further reference.

- Unpack the equipment carefully and save the original box and packing material for possible future shipment.
- Follow basic safety precautions to reduce the risk of fire, electrical shock and injury to persons.
- Do not dismantle the housing or modify the module. It may result in electrical shock or burn.
- Using supplies or parts not meeting the specifications of product may cause damage, deterioration or malfunction.
- Refer all servicing to qualified service personnel.
- To prevent fire or shock hazard, do not expose the unit to rain, moisture or install this product near water.
- Do not put any heavy items on the extension cable in case of extrusion.
- Do not remove the housing of the device as opening or removing housing may expose you to dangerous voltage or other hazards.
- Install the device in a place with fine ventilation to avoid damage caused by overheat.
- Keep the module away from liquids.
- Spillage into the housing may result in fire, electrical shock, or equipment damage. If an object or liquid falls or spills on to the housing, unplug the module immediately.
- Do not twist or pull by force ends of the optical cable. It can cause malfunction.
- Do not use liquid or aerosol cleaners to clean this unit. Always unplug the power to the device before cleaning.
- Unplug the power cord when left unused for a long period of time.
- Information on disposal for scrapped devices: do not burn or mix with general household waste, and please treat them as normal electrical wastes.

8x8 HDMI 2.0 HDBaseT Matrix Switcher

Table of Contents

1. Product Introduction	1
1.1 Features	1
1.2 Package List.....	2
2. Specification	3
2.1 Matrix Switcher.....	3
2.2 HDBaseT Receiver.....	4
3. Panel Description	6
3.1 Matrix Switcher Front Panel	6
3.2 Matrix Switcher Rear Panel.....	7
3.3 Receiver Front and Rear Panel.....	8
4. System Connection	10
4.1 Usage Precaution.....	10
4.2 System Diagram.....	10
5. Button Control.....	11
5.1 Signal Switching	11
5.2 Panel Button Locking/Unlocking.....	12
5.3 Status Information Inquiry	12
5.4 EDID Management.....	13
5.5 Audio Setting	15
5.6 Preset Setting.....	17
5.7 IP Address Inquiry	18
6. GUI Control.....	19
6.1 Signal Switching	20
6.2 Audio Setting	21
6.3 Configuration	23
6.3.1 Down-scaling.....	23
6.3.2 HDCP Setting	24
6.3.3 EDID Copy	25
6.3.4 EDID Setting	26

8x8 HDMI 2.0 HDBaseT Matrix Switcher

6.4 CEC Control	27
6.5 RS232 Control.....	30
6.6 Access Setting.....	31
6.7 Interface Setting	32
6.8 Network Setting	33
6.9 GUI Upgrade	34
7. IR Control	35
7.1 IR Remote Control.....	35
7.2 IR Pass-through Control.....	35
7.2.1 Control Local Input Device from Remote	36
7.2.2 Control Remote Output Device from Local	38
8. RS232 Control	40
8.1 RS232 Control Connection.....	40
8.1.1 Control the Matrix Switcher from Local	40
8.1.2 Control the Matrix Switcher from Remote	41
8.1.3 Control the Remote Third-party Device from Local	42
8.1.4 Control the Local Third-party Device from Remote	43
8.2 RS232 Control Software.....	44
8.3 RS232 Commands	45
8.3.1 System Setting	45
8.3.2 Signal Switching.....	48
8.3.3 Audio Setting	50
8.3.4 HDCP Setting	54
8.3.5 EDID Management.....	55
8.3.6 Third-party Device Control	56
8.3.7 CEC Control	57
9. Firmware Upgrade	60
10. Panel Drawing	61
11. Troubleshooting & Maintenance	62
12. Customer Service	63

8x8 HDMI 2.0 HDBaseT Matrix Switcher

1. Product Introduction

Thanks for choosing the professional 8x8 HDMI 2.0 HDBaseT matrix switcher with eight receivers! The matrix is an eight-input by eight-output HDBaseT and HDMI matrix with HDCP 2.2 and up to 4K/UHD@60Hz video support. It transmits 4K video to distances up to 131 feet (40 meters) and 1080p video to distances up to 230 feet (70 meters) over a single CATx Ethernet cable. The eight HDBaseT outputs support 24V Power over Cable (PoC) feature, allowing the receivers to draw their power from the matrix over the HDBaseT cable.

The matrix switcher features comprehensive EDID management and advanced HDCP handling to ensure maximum functionality with a wide range of video sources.

The matrix switcher not only supports bi-directional IR, RS232 extension but also has IR, RS232, and TCP/IP control options.

The product provides performance in control and transmission, which could be used in a number of different installation scenarios, for example, with computers, for monitoring purposes, large screen displays, conference systems, television education, bank security institutions, etc.

1.1 Features

- 8x8 HDBaseT matrix switcher with audio matrix.
- Fully compliant with the HDMI 2.0 and HDCP 2.2.
- Supports HDMI resolution up to 4K@60Hz 4:4:4, HDR10.
- Features eight mirrored HDMI outputs for eight HDBaseT outputs, and the eight HDMI outputs support 4K to 1080p down-scaling.
- The eight HDBaseT outputs support 24V PoC, allowing the receivers to draw their power from the matrix switcher over the HDBaseT cable.
- Transmits 4K signal to the distance up to 131 feet (40 meters) and 1080p signal to the distance up to 230 feet (70 meters) over a single CATx Ethernet cable.
- Supports audio matrix. Provides eight digital SPDIF audio outputs and eight analog L+R audio outputs for HDMI input audio de-embedding and HDBaseT output audio de-embedding. Moreover, the eight digital SPDIF audio outputs supports ARC audio output from receivers.
- Volume adjustment for analog L+R audio outputs.
- Supports comprehensive EDID management and advanced HDCP handling.
- Controllable via front panel buttons, RS232 local and pass-through, IR local and pass-through, CEC, and TCP/IP (built-in GUI).

8x8 HDMI 2.0 HDBaseT Matrix Switcher

1.2 Package List

<p>HDBaseT Matrix Switcher</p>	<ul style="list-style-type: none"> • 1x MUH88T-H2 8x8 HDMI 2.0 HDBaseT Matrix Switcher • 2x Mounting Ears with 6 Screws • 4x Plastic Cushions with 4 Screws • 1x IR Receiver • 1x IR Remote • 1x RS232 Cable (3-pin to DB9) • 16x 3-pin Terminal Blocks • 1x Power Cord
<p>HDBaseT Receiver</p>	<ul style="list-style-type: none"> • 8x TPUH610SR HDBaseT Receivers • 16x Mounting Ears with 32 Screws • 32x Plastic Cushions • 8x 3-pin Terminal Blocks
	<ul style="list-style-type: none"> • 1x User Manual

Note: Please contact your distributor immediately if any damage or defect in the components is found.

2. Specification

2.1 Matrix Switcher

Video Input	
Input	(8) HDMI
Input Connector	(8) Type-A female HDMI
HDMI Input Resolution	Up to 4Kx2K@60Hz 4:4:4, HDR10,1080p 3D
Video Output	
Output	(8) HDBaseT, (8) HDMI
Output Connector	(8) RJ45, (8) Type-A female HDMI
HDMI Output Resolution	Up to 4Kx2K@60Hz 4:4:4, HDR10, 1080p 3D. Supports 4K to 1080p down-scaling.
HDBaseT Output Resolution	Up to 4Kx2K@60Hz 4:2:0
HDMI Audio Signal	LPCM 7.1 audio, Dolby Atmos®, Dolby® TrueHD, Dolby Digital® Plus, DTS:X™, and DTS-HD® Master Audio™ pass-through.
Audio Output	
Output	(8) Stereo analog L+R audio, (8) Digital SPDIF audio
Output Connector	(8) 3-pin terminal blocks, (8) Toslink connectors
Analog L+R Audio Format	Supports PCM
Digital SPDIF Audio Format	Supports PCM, Dolby Digital, DTS, DTS-HD
Local Audio Sampling Rate	Supports 44.1KHz, 48KHz, 96KHz
ARC Audio Sampling Rate	Supports 48KHz, 96KHz
Frequency Response	20Hz – 20KHz, ±3dB
Audio Output Impedance	70Ohms
Max Input Level	L+R: 2.0Vrms ± 0.5dB. 2V = 16dB headroom above -10dBV (316mV) nominal consumer line level signal. SPDIF: ± 0.05dBFS.
THD+N	< 0.05% (-80dB), 20Hz – 20KHz bandwidth, 1KHz sine at 0dBFS level (or max level).
SNR	L+R: > 80dB, 20Hz - 20KHz bandwidth. SPDIF: > 90dB, 20Hz-20 kHz bandwidth.
Crosstalk Isolation	SPDIF: < -70 dB, 10KHz sine at 0dBFS level (or max level before clipping). L+R: < -80 dB, 10KHz sine at 0dBFS level (or max level before clipping).
L-R Level Deviation	L+R: < 0.3dB, 1KHz sine at 0dBFS level (or max level before clipping).
Frequency Response Deviation	< ± 0.5dB 20Hz - 20KHz.

8x8 HDMI 2.0 HDBaseT Matrix Switcher

Output Load Capability	L+R: 1K Ω and higher (Supports 10x paralleled 10K Ω loads).
Stereo Channel Separation	>70dB@1KHz.
Noise Level	L+R: -80dB; SPDIF: -90dB
Control Part	
Control port	(8) IR IN, (1) IR ALL IN, (8) IR OUT, (1) IR ALL OUT, (1) IR EYE, (9) RS232, (1) FIRWARE, (1) TCP/IP
Control Connector	(19) 3.5mm jacks, (9) 3-pin terminal blocks, (1) Type-A USB, (1) RJ45
General	
Transmission Mode	HDBaseT
Transmission Distance	1080p \leq 230 feet (70 meters), 4K@60Hz \leq 131 feet (40 meters)
Bandwidth	18Gbps
Operation Temperature	-5 $^{\circ}$ C ~ +55 $^{\circ}$ C
Storage Temperature	-25 $^{\circ}$ C ~ +70 $^{\circ}$ C
Relative Humidity	10% ~ 90%
External Power Supply	100V~240V AC, 50/60Hz
Power Consumption	125W (Max)
Dimension (W*H*D)	436.6mm x 88mm x 440mm
Net Weight	5.8kg

2.2 HDBaseT Receiver

Video	
Input	(1) HDBT
Input Connector	(1) RJ45
Input Resolution	Up to 4Kx2K@60Hz 4:2:0
Output	(1) HDMI
Output Connector	(1) Type-A female HDMI
Output Resolution	Up to 4Kx2K@60Hz 4:4:4 8bit, HDR10
Audio	
Input	(1) ARC Audio In
Input Connector	(1) Toslink Connector
Output	(1) Audio Breakout
Output Connector	(1) Toslink connector
Audio Format	Supports PCM, Dolby Digital, Dolby True-HD, DTS and DTS-HD.

8x8 HDMI 2.0 HDBaseT Matrix Switcher

Frequency Response	20Hz – 20KHz, ± 3 dB
Max Output Level	2.0Vrms \pm 0.5dB. 2V = 16dB headroom above -10dBV (316mV) nominal consumer line level signal
THD+N	< 0.05% (-80dB), 20Hz – 20KHz bandwidth, 1KHz sine at 0dBFS level (or max level)
SNR	> 85dB, 20Hz-20 kHz bandwidth
Crosstalk Isolation	> 70dB, 10KHz sine at 0dBFS level (or max level before clipping)
L-R Level Deviation	< 0.3dB, 1KHz sine at 0dBFS level (or max level before clipping)
Frequency Response Deviation	< \pm 0.5dB 20Hz - 20KHz
Output Load Capability	1K Ω and higher (Supports 10x paralleled 10K Ω loads)
Stereo Channel Separation	>70dB@1KHz
Control	
Control Part	(1) ARC Mode button, (1) FW, (1) IR In, (1) IR Out, (1) RS232
Control Connector	(1) Micro-USB port, (2) 3.5mm jacks, (1) 3-pin terminal block
General	
Bandwidth	18Gbps
HDMI Standard	2.0
HDCP Version	2.2, 1.4 compliant
CEC	Pass-through
Bidirectional PoC	Supported
HDMI 2.0 Cable Length	4K@60Hz 4:4:4 \leq 5m, 4K@60Hz 4:2:0 \leq 15m, 1080p \leq 20m
Transmission Standard	HDBaseT
Transmission Distance	1080p@60Hz \leq 230 feet (70 meters), 4K@60Hz \leq 131 feet (40 meters)
Operation Temperature	-5°C ~ +55°C
Storage Temperature	-25°C ~ +70°C
Relative Humidity	10%-90%
Power Supply	Input:100V~240V AC; Output:24V DC 1.25A
Power Consumption	12W (Max)
Dimension (W*H*D)	40mm x 19.5mm x 84mm
Net Weight	290g

8x8 HDMI 2.0 HDBaseT Matrix Switcher

3. Panel Description

3.1 Matrix Switcher Front Panel

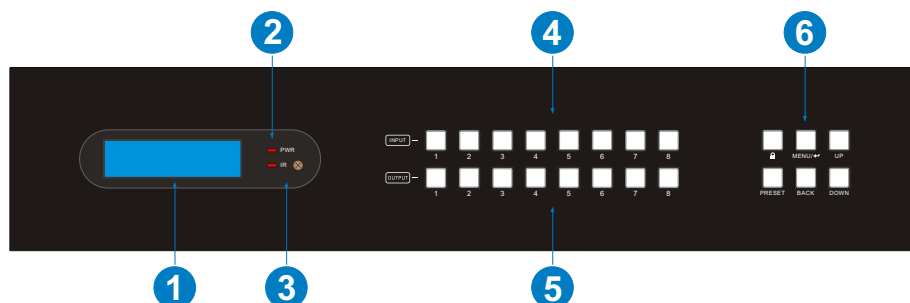

- ① **LCD Screen:** Presents real-time operation status.
- ② **Power LED:** Illuminates RED when the device is in standby mode, illuminates GREEN when device is powered on.
- ③ **IR Sensor and its LED:** Illuminates RED when the IR sensor receives an IR signal from the IR remote to control the matrix switcher. The IR sensor is on the right side of the LED.
- ④ **INPUT:** Eight buttons for input source selection.
- ⑤ **OUTPUT:** Eight buttons for output channel selection.
- ⑥ **Menu Buttons:**
 - LOCK: Lock or unlock the front panel buttons.
 - PRESET: Preset setting.
 - MENU/↵: Menu or confirm button.
 - BACK: Go back to the previous operation.
 - UP: Page up.
 - DOWN: Page down.

8x8 HDMI 2.0 HDBaseT Matrix Switcher

3.2 Matrix Switcher Rear Panel

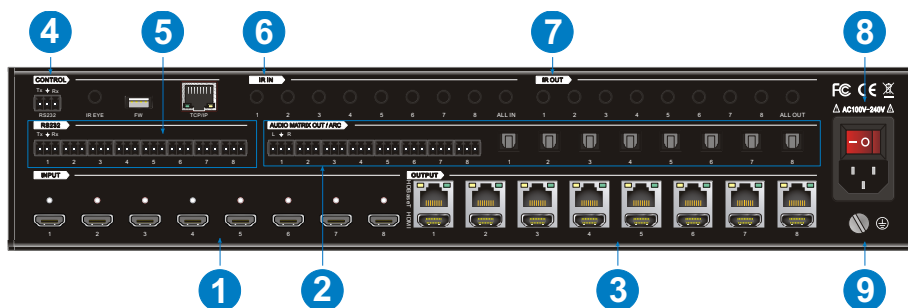

- ① **INPUT:** Eight type-A female HDMI input ports to connect HDMI sources.
- ② **AUDIO MATRIX OUT/ARC:** Eight 3-pin terminal blocks and eight Toslink connectors to connect speakers or amplifiers for HDMI input audio de-embedding or HDBaseT output audio de-embedding, and the eight Toslink connectors can also be used for ARC audio output from HDBaseT receivers. They can make up an audio matrix to be set by front panel buttons, GUI or RS232 commands.
- ③ **OUTPUT:** Eight HDBaseT RJ45 outputs to connect the eight HDBaseT receivers, and eight local HDMI ports to connect local displays.
- ④ **CONTROL:**
 - RS232: 3-pin terminal block to connect the control device (e.g. PC) to control the matrix switcher by RS232 commands.
 - IR EYE: 3.5mm jack to connect IR receiver to control the matrix switcher by the IR remote.
 - FW: Type-A USB port for firmware upgrade.
 - TCP/IP: RJ45 port to connect the control device (e.g. PC) to control the matrix switcher by GUI.
- ⑤ **RS232:** Eight 3-pin terminal blocks to control the third-party devices base on RS232 pass-through feature. There is a one-to-one correspondence between the eight RS232 ports and the eight RS232 ports of eight HDBaseT receivers.
- ⑥ **IR IN:**
 - 1~8: Eight 3.5mm jacks to connect eight IR receivers. Each IR input is associated with the respective HDBaseT output and cannot be switched separately. It makes up a bi-directional IR transmission with the IR OUT on the corresponding HDBaseT receiver.
 - ALL IN: 3.5mm jack to connect the IR receiver to transmit the IR signal from the

8x8 HDMI 2.0 HDBaseT Matrix Switcher

ALL IN port to all HDBaseT receivers.

⑦ IR OUT:

- 1~8: Eight 3.5mm jacks to connect eight IR emitters to send the IR signal received from the corresponding HDBaseT receivers.
- ALL OUT: 3.5mm jack to connect the IR emitter to send the IR signal received from all HDBaseT receivers.

⑧ AC100V~240V: Power port to connect an AC 100V~240V power by the power cord.

⑨ GROUND: Connect to earth to ensure the unit is well grounded.

3.3 Receiver Front and Rear Panel

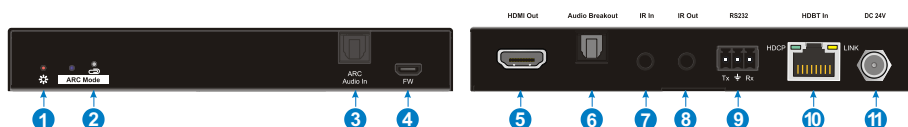

① Power LED: The LED illuminates red when power is applied.

② ARC Mode: Press the button with paper clip or other sharp tool to enable the ARC mode, and then the left LED illuminates blue. Press it again to exit the ARC mode and the LED is off. When the ARC audio is selected as the audio source for the SPDIF output of matrix switcher, the ARC mode will be enabled automatically.

③ ARC Audio In: Toslink connector to connect ARC audio source device (e.g.TV).

④ FW: Micro-USB port for firmware upgrade.

⑤ HDMI Out: Type-A female HDMI output port to connect HDMI display (e.g.TV).

⑥ Audio Breakout: If the ARC mode is OFF, the Toslink connector is connected to speaker or amplifier for HDMI source audio de-embedding. Note that if the ARC mode is ON, this port has no audio output.

⑦ IR In: 3.5mm jack to connect the IR receiver for IR pass-through.

⑧ IR Out: 3.5mm jack to connect the IR emitter for IR pass-through.

⑨ RS232: 3-pin terminal block to connect the RS232 control device (e.g. PC) or a third-party device to be controlled.

8x8 HDMI 2.0 HDBaseT Matrix Switcher

- ⑩ **HDBT In:** RJ45 port to connect the HDBT output port of switcher/transmitter by CATx Ethernet cable. The LINK LED illuminates orange when there is a valid HDBaseT link between the switcher/transmitter and the receiver. The HDCP LED illuminates green when the video contains HDCP content.
- ⑪ **DC 24V:** DC connector for the power adaptor connection. If the switcher/transmitter is connected to the power adaptor, the receiver doesn't need to connect power adaptor due to the HDBT output port of switcher/transmitter supports 24V PoC output.

8x8 HDMI 2.0 HDBaseT Matrix Switcher

4. System Connection

4.1 Usage Precaution

- Make sure all components and accessories included before installation.
- System should be installed in a clean environment with proper temperature and humidity.
- All of the power switches, plugs, sockets, and power cords should be insulated and safe.
- All devices should be connected before power on.

4.2 System Diagram

The following diagram illustrates typical input and output connections that can be utilized with this matrix switcher:

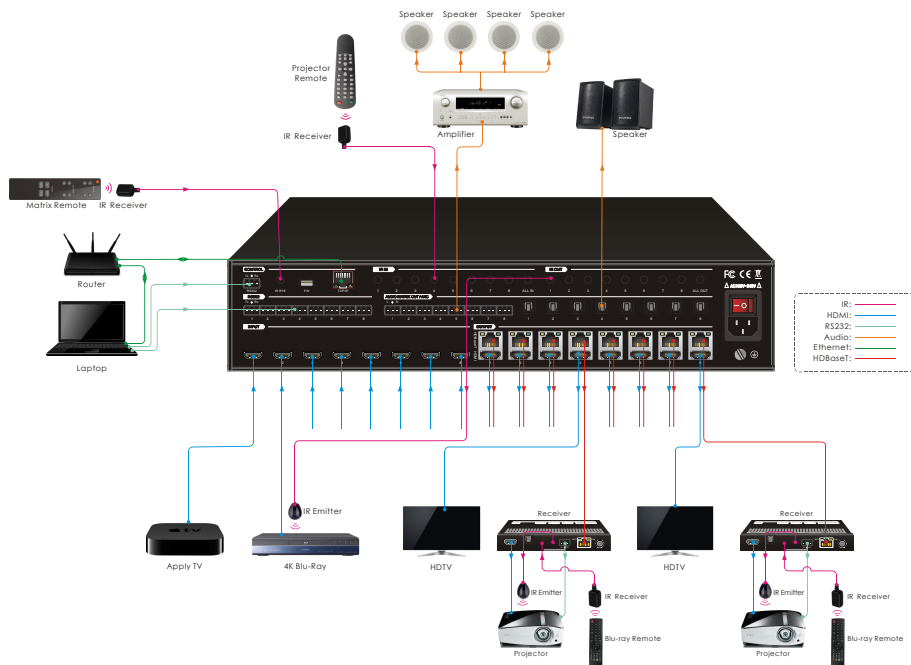

8x8 HDMI 2.0 HDBaseT Matrix Switcher

5. Button Control

The matrix switcher can be controlled by using the buttons on the front panel. Whenever a command is accepted, the indicators of all the buttons pressed will blink three times then they will go off. If the command fails, the indicators will go off immediately without blinking.

5.1 Signal Switching

- **Switch an input to an output**

Operation: INPUT# + OUTPUT# + MENU/↵

Example: Switch Input 1 to Output 2:



Note: In default status, 8 IR OUT ports correspond with 8HDMI INPUTS. When you switch an HDMI input, the corresponding IR OUT will be switched synchronously.

- **Switch an input to several outputs**

Operation: INPUT# + OUTPUT# + OUTPUT# +... + MENU/↵

Example: Switch Input 1 to Output 2, 3, and 4.

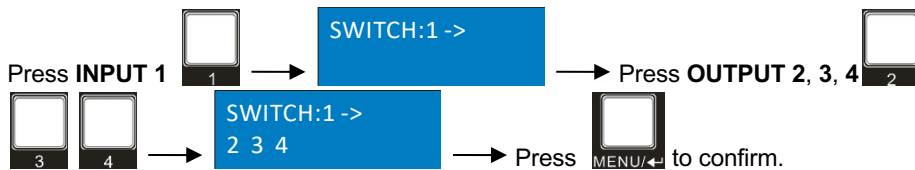





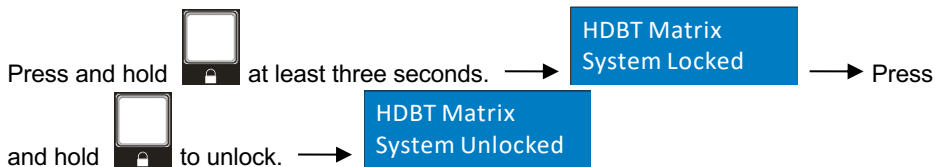

8x8 HDMI 2.0 HDBaseT Matrix Switcher

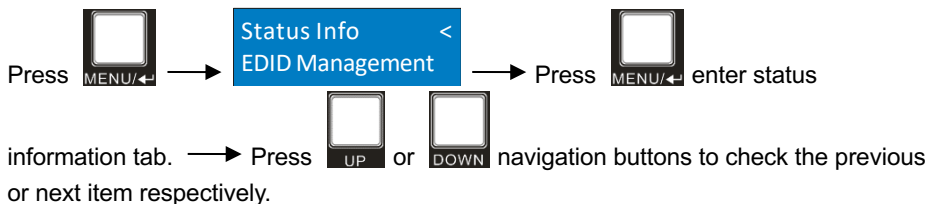
5.2 Panel Button Locking/Unlocking

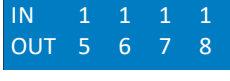

5.3 Status Information Inquiry



LCD Screen	Description
 	Report the signal switching status.
 	Report the connection status of all HDMI input ports. Y means the corresponding input port is connected to a source device, N means there is no connection between the input port and source device.
  1~8=HDBaseT output 1~8.	Report the connection status of all HDBT output ports. Y means the corresponding output port is connected to an HDBaseT receiver, N means there is no connection between the output port and HDBaseT receiver.

8x8 HDMI 2.0 HDBaseT Matrix Switcher

OUT 9 10 11 12 LINK Y Y Y Y	Report the connection status of all HDMI loop output ports. Y means the corresponding output port is connected to a display device, N means there is no connection between the output port and display device.
OUT 13 14 15 16 LINK Y Y Y Y	
9~16=HDMI loop output 1~8.	

5.4 EDID Management

The Extended Display Identification Data (EDID) is used by the source device to match its video resolution with the connected display. By default, the eight source devices invoke the fifth built-in EDID: 4K@60Hz HDR 2CH.

• Enter EDID management tab:

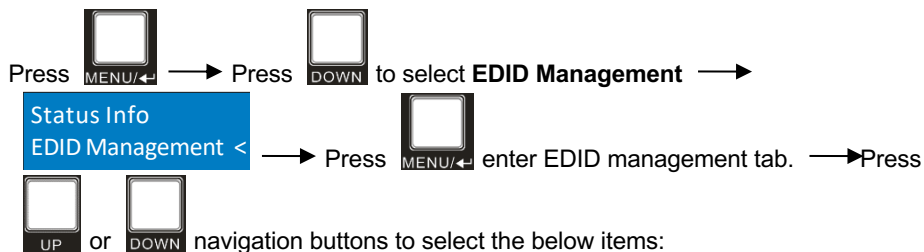

- ✓ Learn HDBT OUT
- ✓ Learn HDMI OUT
- ✓ Built-in EDID

• To copy the EDID data from one HDBT output to one or several inputs:

Example: Input 1, 2, 3 and 4 learn the EDID data of HDBT output 2.

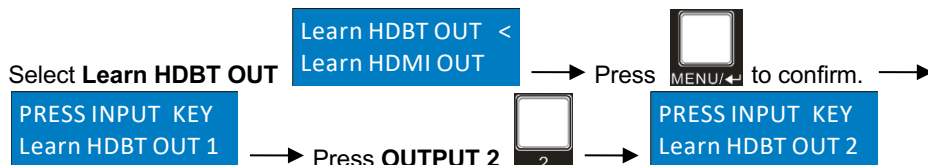

8x8 HDMI 2.0 HDBaseT Matrix Switcher

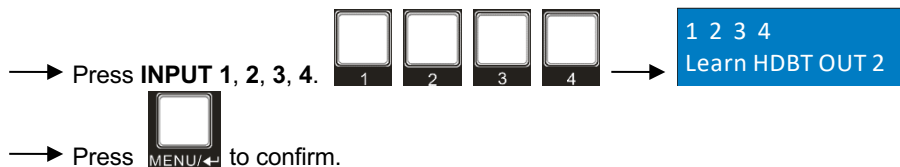

- **To copy the EDID data from one HDMI output to one or several inputs:**

Example: Input 1 and 2 learn the EDID data of HDMI output 4.

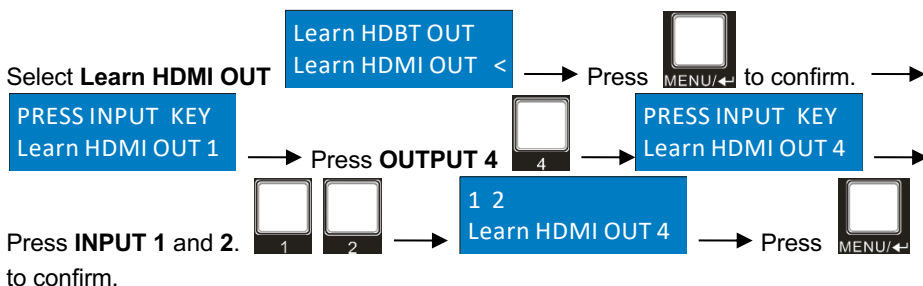

- **To invoke the built-in EDID data:**

There are six types of built-in EDID data can be invoked, as shown as below:

No.	EDID	
	Video	Audio
1	1080p	2CH
2	1080p HDR	MultiCH
3	4K@30Hz HDR	2CH
4	4K@60Hz HDR	MultiCH
5 (Default)	4K@60Hz HDR	2CH
6	4K@60Hz HDR	MultiCH
	User Custom	

Example: Input 1 and 2 invoke the built-in EDID data: 4K@30Hz HDR 2CH.

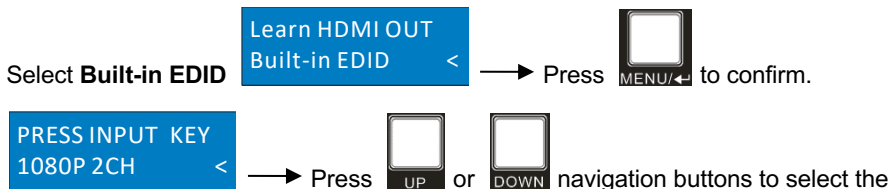

8x8 HDMI 2.0 HDBaseT Matrix Switcher

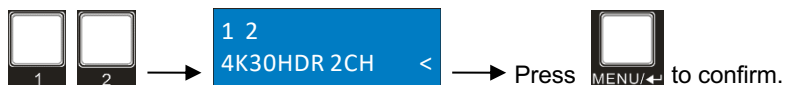
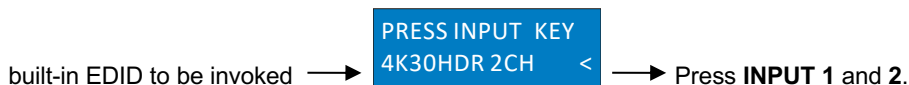

5.5 Audio Setting

The matrix switcher provides eight analog L+R audio output ports and eight digital SPDIF output ports for audio de-embedding. The audio source selection of these eight audio output ports, and the L+R audio volume can be controlled by the front panel buttons.

- **Audio Source Selection**

There are sixteen audio sources can be selected for any analog L+R audio output port, and twenty-four audio sources can be selected for any SPDIF audio output port.

Audio Output Ports	Audio Sources		
	Input Breakout	Output Breakout	ARC
L+R OUT 1	In1 Breakout	Out1 Breakout	/
L+R OUT 2	In2 Breakout	Out2 Breakout	
L+R OUT 3	In3 Breakout	Out3 Breakout	
L+R OUT 4	In4 Breakout	Out4 Breakout	
L+R OUT 5	In5 Breakout	Out5 Breakout	
L+R OUT 6	In6 Breakout	Out6 Breakout	
L+R OUT 7	In7 Breakout	Out7 Breakout	
L+R OUT 8	In8 Breakout	Out8 Breakout	
SPDIF OUT 1	In1 Breakout	Out1 Breakout	Out1 ARC
SPDIF OUT 2	In2 Breakout	Out2 Breakout	Out2 ARC
SPDIF OUT 3	In3 Breakout	Out3 Breakout	Out3 ARC
SPDIF OUT 4	In4 Breakout	Out4 Breakout	Out4 ARC
SPDIF OUT 5	In5 Breakout	Out5 Breakout	Out5 ARC
SPDIF OUT 6	In6 Breakout	Out6 Breakout	Out6 ARC
SPDIF OUT 7	In7 Breakout	Out7 Breakout	Out7 ARC
SPDIF OUT 8	In8 Breakout	Out8 Breakout	Out8 ARC

8x8 HDMI 2.0 HDBaseT Matrix Switcher

Example: Select the HDMI input 2 audio source for the analog L+R output 2.

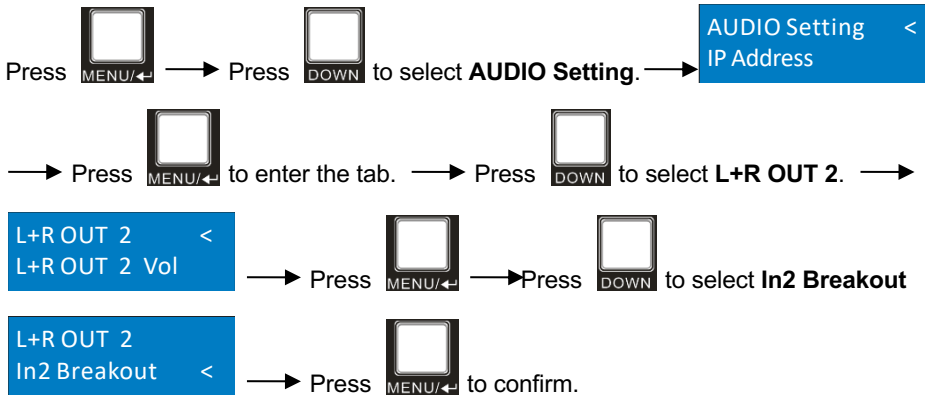

- **L+R Output Audio Volume Control**

Example: Set the audio volume of L+R OUT 2 port.

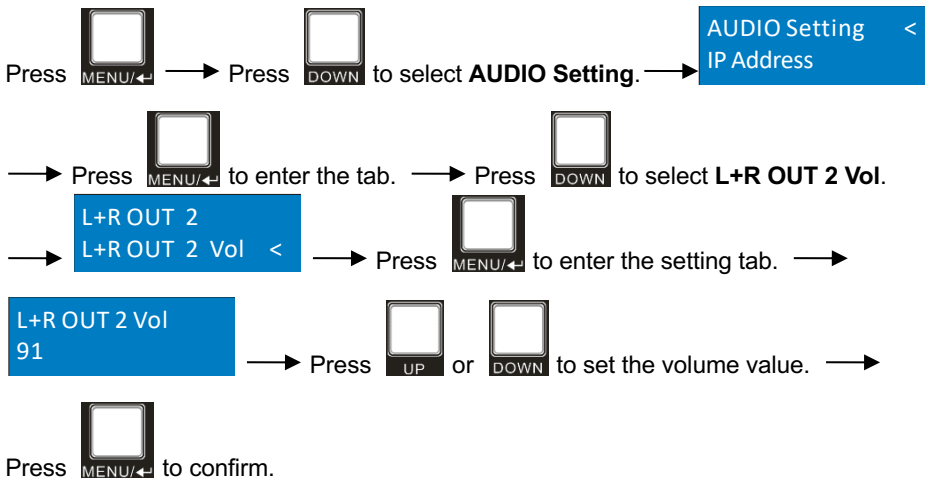

8x8 HDMI 2.0 HDBaseT Matrix Switcher

5.6 Preset Setting

Press **PRESET** button can save the current switching routing or load the saved layout preset.

Note: The matrix switcher supports nine presets, but only preset 1~4 can be saved and recalled by button control. Please manage other preset by GUI control or RS232 control.

• **Save the current switching routing to a preset**

Example: Save the current switching routing to preset 2.

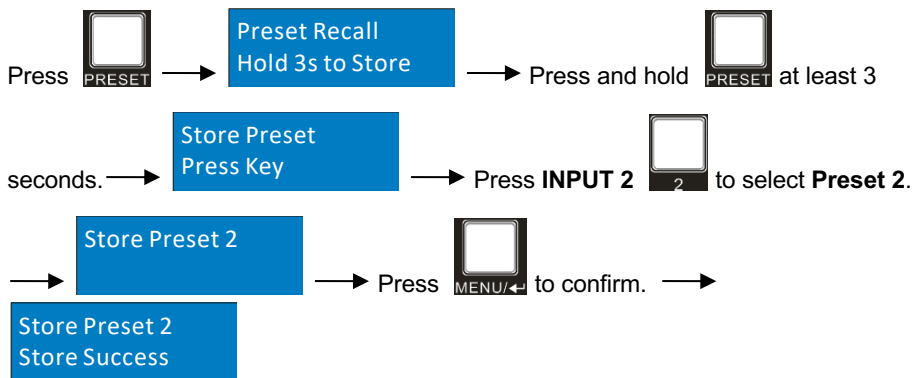

• **Recall a saved preset**

Example: Recall the saved preset 2.

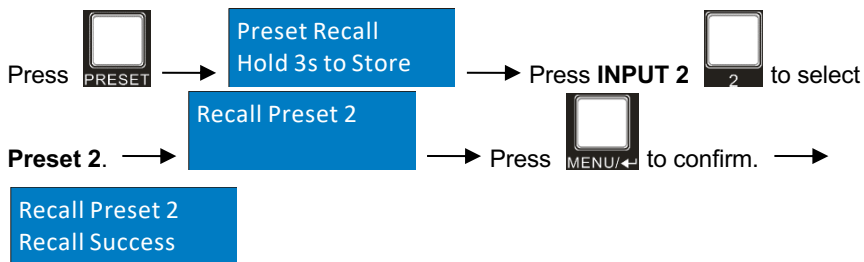

8x8 HDMI 2.0 HDBaseT Matrix Switcher

5.7 IP Address Inquiry



8x8 HDMI 2.0 HDBaseT Matrix Switcher

6. GUI Control

The switcher can also be controlled via TCP/IP. The default IP settings are:

IP Address: 192.168.0.178

Subnet Mask: 255.255.255.0

Type **192.168.0.178** in the internet browser, it will enter the below log-in webpage:

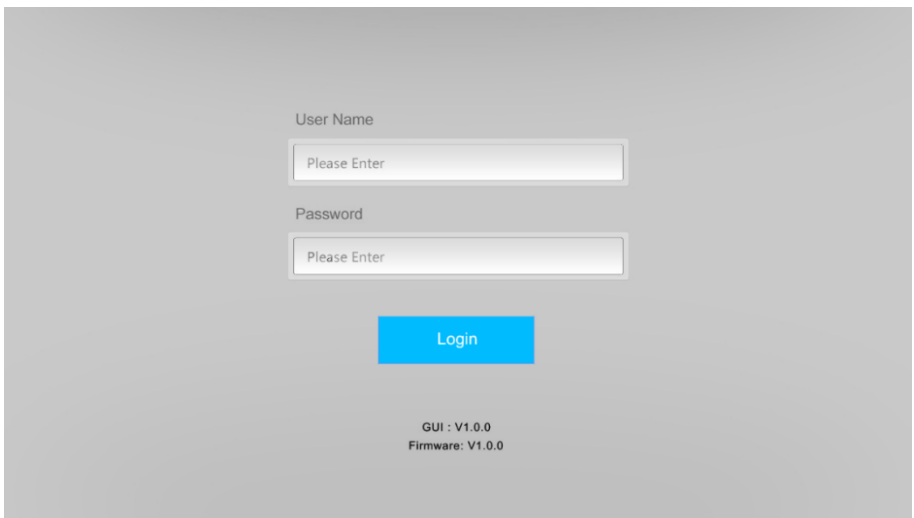

User Name
Please Enter

Password
Please Enter

Login

GUI : V1.0.0
Firmware: V1.0.0

Username: admin

Password: admin

Type the user name and password, and then click **Login** to enter the section for video switching.

8x8 HDMI 2.0 HDBaseT Matrix Switcher

6.1 Signal Switching

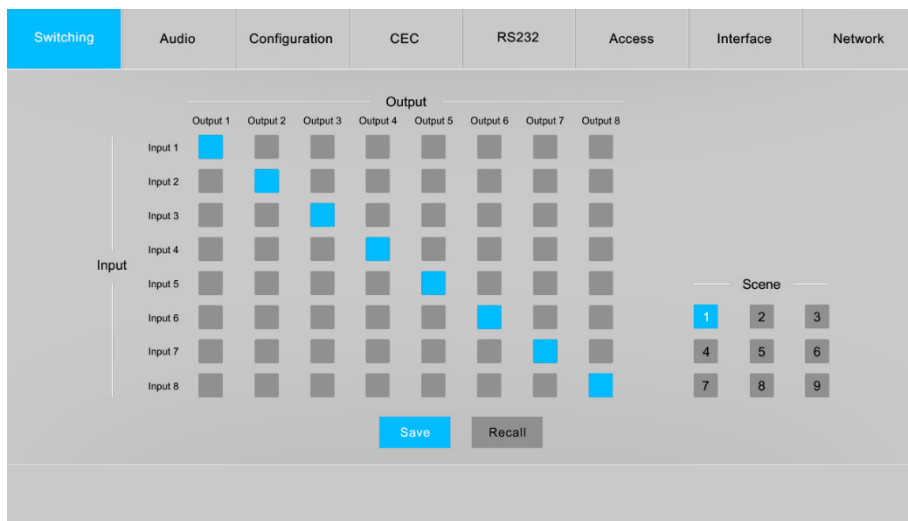

Use the 8x8 button grid on the page to set which inputs are directed to which outputs. For example, clicking the button on the Input 1 row and Output 1 column, directs input 1 to output 1.

Use the 9 numbered buttons under scene area to save and load layout presets.

- To save a given layout, first click one of the numbered buttons, then click the **Save** button.
- To load a previously saved layout, first click one of the numbered buttons, then click the **Recall** button.

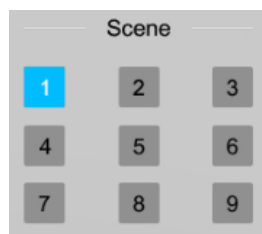

8x8 HDMI 2.0 HDBaseT Matrix Switcher

6.2 Audio Setting

- **Audio Source Selection**

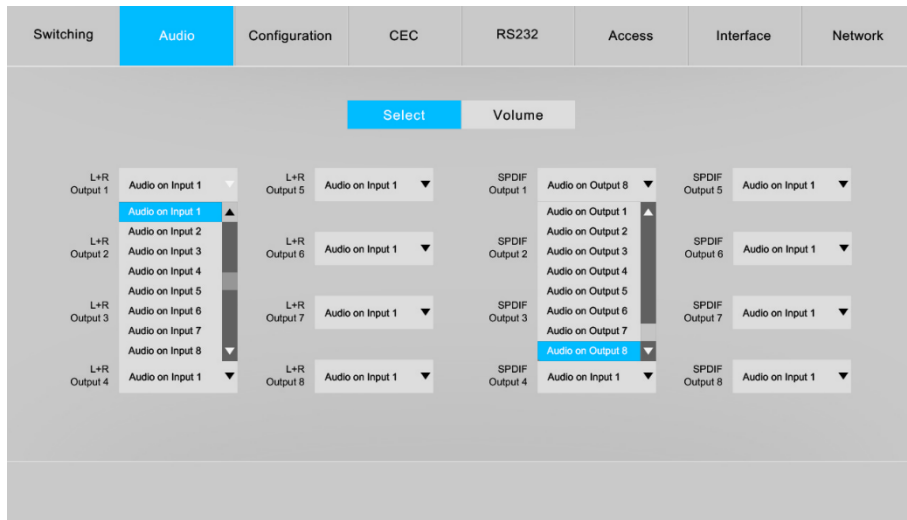

- There are sixteen audio sources can be selected for eight analog L+R audio output ports, and twenty-four audio sources can be selected for eight digital SPDIF output ports.

8x8 HDMI 2.0 HDBaseT Matrix Switcher

- L+R Output Audio Volume Control

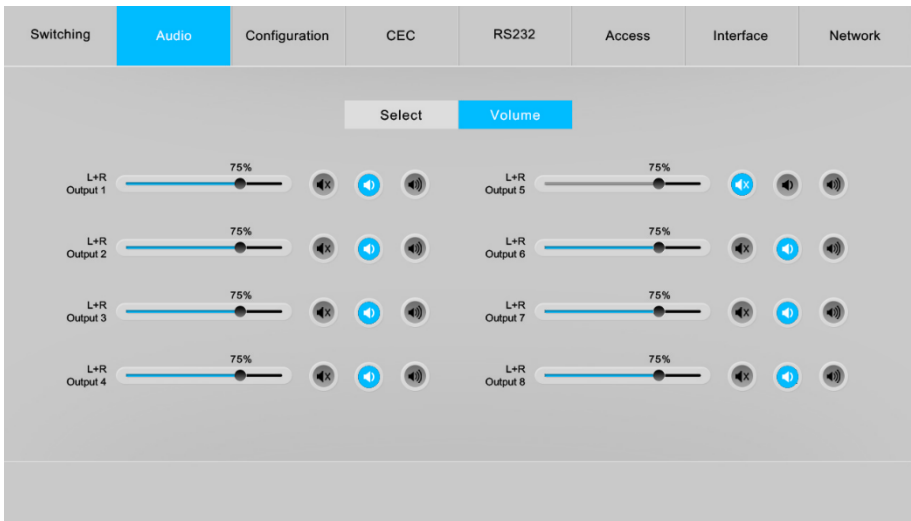

- Adjust L+R output audio volume by the volume bar and the three buttons on the right side.

8x8 HDMI 2.0 HDBaseT Matrix Switcher

6.3 Configuration

6.3.1 Down-scaling

Switching	Audio	Configuration	CEC	RS232	Access	Interface	Network
		Down-scaling	HDCP	EDID Copy	EDID Setting		
			Enable	Disable		Enable	Disable
		HDMI Output 1	<input checked="" type="radio"/>	<input type="radio"/>	HDMI Output 5	<input checked="" type="radio"/>	<input type="radio"/>
		HDMI Output 2	<input checked="" type="radio"/>	<input type="radio"/>	HDMI Output 6	<input checked="" type="radio"/>	<input type="radio"/>
		HDMI Output 3	<input checked="" type="radio"/>	<input type="radio"/>	HDMI Output 7	<input checked="" type="radio"/>	<input type="radio"/>
		HDMI Output 4	<input checked="" type="radio"/>	<input type="radio"/>	HDMI Output 8	<input checked="" type="radio"/>	<input type="radio"/>
			<input type="button" value="Confirm"/> <input type="button" value="Cancel"/>				

- Enable/disable video resolution down-scaling function of HDMI output 1~8 ports.
When enable down-scaling, the 4K input can be automatically degraded to 1080p output for compatibility with 1080p display which is connected to the HDMI output port.

8x8 HDMI 2.0 HDBaseT Matrix Switcher

6.3.2 HDCP Setting

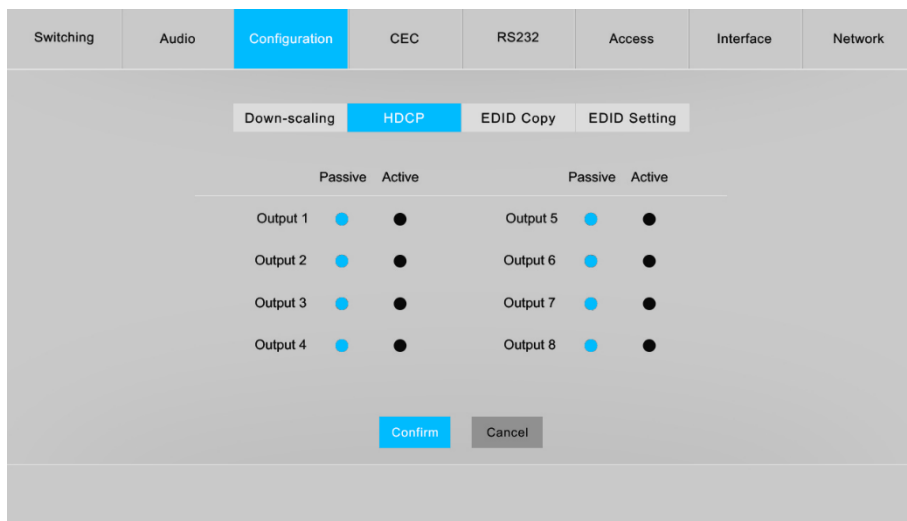

- Set the HDCP mode of HDMI and HDBaseT outputs to **Passive** or **Active**.

Mode	Description
Passive	Automatically follows the HDCP version of source device.
Active (Default)	<ul style="list-style-type: none"> If the input video has HDCP content, the HDCP version of HDMI output is HDCP 1.4 for broader video solution. If the input video has no HDCP content, the HDMI output has no HDCP too.

Click **Confirm** to save any changes or click **Cancel** to cancel any changes that have been made.

8x8 HDMI 2.0 HDBaseT Matrix Switcher

6.3.3 EDID Copy

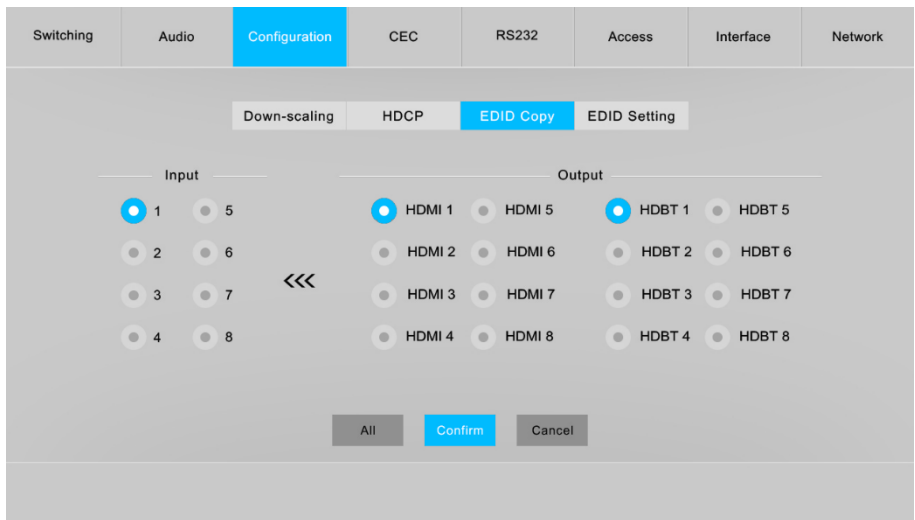

- Copy the EDID data from a single output port to one or several input ports.

Operation:

- 1) Select one output port.
- 2) Select one or several input ports. Press **ALL** to select all input ports.
- 3) Click **Confirm** to save any changes or click **Cancel** to cancel any changes that have been made.

8x8 HDMI 2.0 HDBaseT Matrix Switcher

6.3.4 EDID Setting

Click **EDID Setting** to enter the below section to set a predefined EDID for input ports.

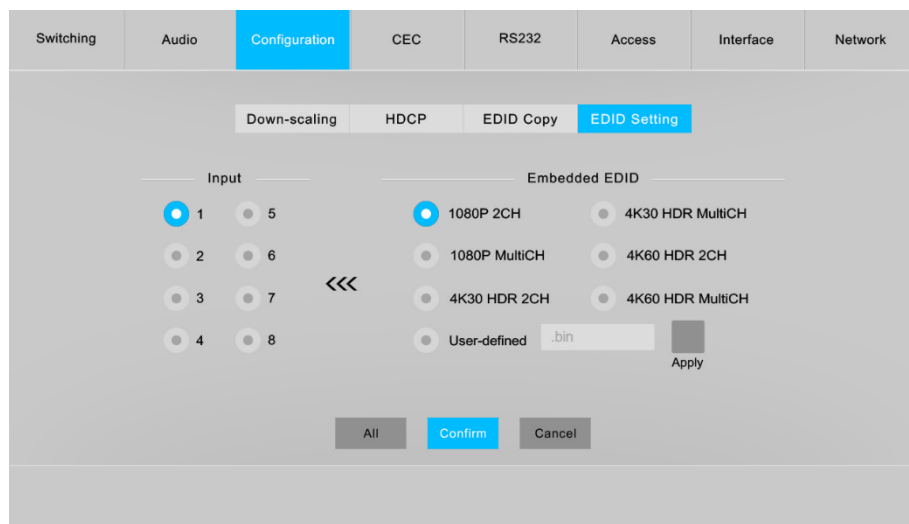

- Select a built-in EDID for one or several input ports.

Operation:

- 1) Select a built-in EDID.
 - 2) Select one or several input ports. Press **ALL** to select all input ports.
 - 3) Click **Confirm** to save setting.
- Upload user-defined EDID by the below steps:
 - 1) Prepare the EDID file (.bin) on the control PC.
 - 2) Select the **User-defined**.
 - 3) Click the box , and then select the EDID file (.bin) according the tooltip.
 - 4) Click **Apply** to upload the user-defined EDID, and then click **Confirm** to save setting.

8x8 HDMI 2.0 HDBaseT Matrix Switcher

6.4 CEC Control

If the input source devices, HDBaseT output devices and local HDMI output devices support CEC, they can be controlled via the following CEC interface.

1) Input Source Device Control

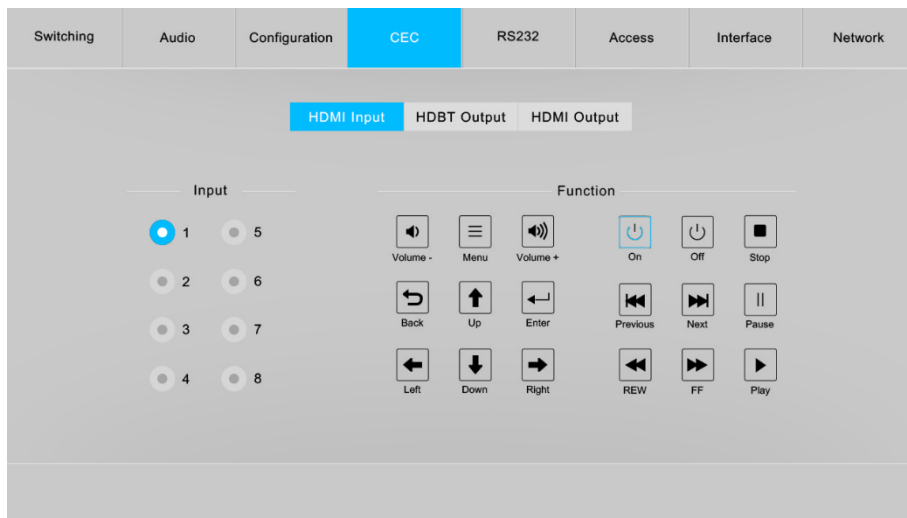

- Select one or several HDMI input source devices to be controlled, and then press function buttons.

8x8 HDMI 2.0 HDBaseT Matrix Switcher

2) HDBT Output Device Control

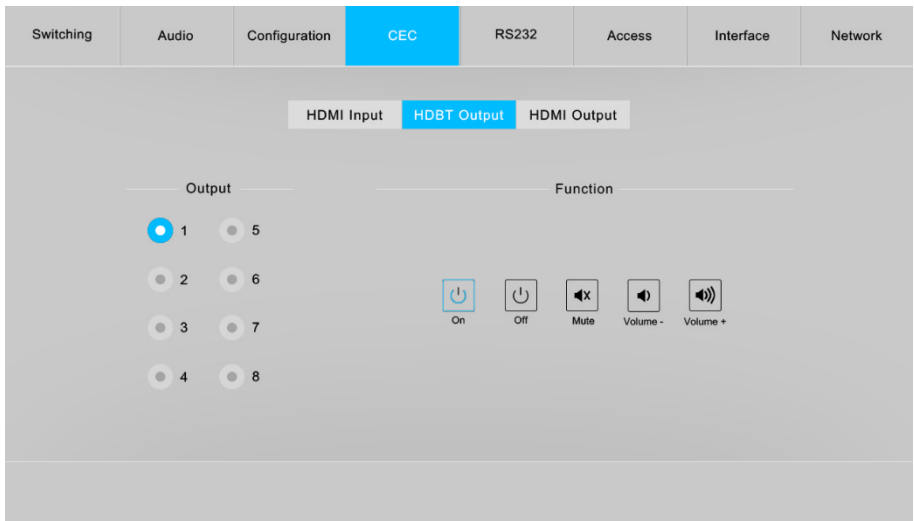

- Select one or several HDBaseT output devices to be controlled, and then press function buttons.

8x8 HDMI 2.0 HDBaseT Matrix Switcher

3) HDMI Output Device Control

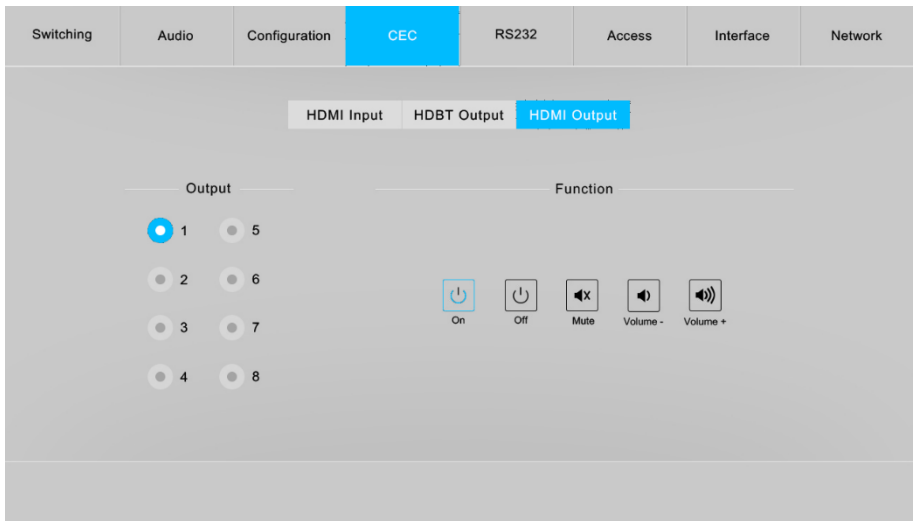

- Select one or several HDMI output devices to be controlled, and then press function buttons.

8x8 HDMI 2.0 HDBaseT Matrix Switcher

6.5 RS232 Control

Switching	Audio	Configuration	CEC	RS232	Access	Interface	Network
<p>Port</p> <p><input checked="" type="radio"/> HDBT 1 <input type="radio"/> HDBT 2 <input type="radio"/> HDBT 3 <input type="radio"/> HDBT 4 <input type="radio"/> HDBT 5 <input type="radio"/> HDBT 6 <input type="radio"/> HDBT 7 <input type="radio"/> HDBT 8</p> <p>Baud Rate</p> <p><input checked="" type="radio"/> 2400 <input type="radio"/> 4800 <input type="radio"/> 9600 <input type="radio"/> 19200 <input type="radio"/> 38400 <input type="radio"/> 57600 <input type="radio"/> 115200</p> <p>Command</p> <p><input type="text"/> Hex <input checked="" type="radio"/></p> <p><input type="button" value="Send"/></p>							

- Send RS232 commands to control third-party devices which are connected to the far-end HDBaseT receivers.

Operation:

- 1) Select the HDBaseT port which is connected to HDBaseT receiver which must have third-party device attached.
- 2) Set the baud rate.
- 3) Typing the commands in the box to control the selected remote third-party device which is connected to HDBaseT receiver. If click the **Hex**, the RS232 commands can be typed with hexadecimal value.
- 4) Click **Send** to transmit RS232 command to the selected HDBaseT port.

8x8 HDMI 2.0 HDBaseT Matrix Switcher

6.6 Access Setting

Switching	Audio	Configuration	CEC	RS232	Access	Interface	Network
Credentials							
Admin Password: <input type="text" value="admin"/>							
User Password: <input type="text" value="user"/>							
Front Panel Lock							
ON <input checked="" type="checkbox"/> OFF							
Version							
GUI : V1.0.0							
Firmware: V1.0.0							
<input type="button" value="Confirm"/> <input type="button" value="Cancel"/>							

- Reset the login admin and user password.
- Lock or unlock the front panel buttons.
- Get the GUI and firmware version.

Click **Confirm** to save any changes or click **Cancel** to cancel any changes that have been made.

8x8 HDMI 2.0 HDBaseT Matrix Switcher

6.7 Interface Setting

Switching	Audio	Configuration	CEC	RS232	Access	Interface	Network
Title Bar Label: <input type="text"/>							
LCD Readout: <input type="text" value="HDBaseT Matrix"/>							
Button Labels:							
Input				Output			
1:	<input type="text" value="Input 1"/>	5:	<input type="text" value="Input 5"/>	1:	<input type="text" value="Output 1"/>	5:	<input type="text" value="Output 5"/>
2:	<input type="text" value="Input 2"/>	6:	<input type="text" value="Input 6"/>	2:	<input type="text" value="Output 2"/>	6:	<input type="text" value="Output 6"/>
3:	<input type="text" value="Input 3"/>	7:	<input type="text" value="Input 7"/>	3:	<input type="text" value="Output 3"/>	7:	<input type="text" value="Output 7"/>
4:	<input type="text" value="Input 4"/>	8:	<input type="text" value="Input 8"/>	4:	<input type="text" value="Output 4"/>	8:	<input type="text" value="Output 8"/>
<input type="button" value="Confirm"/> <input type="button" value="Cancel"/>							

- Modify title bar label, LCD readout and button labels.

Click **Confirm** to save any changes or click **Cancel** to cancel any changes that have been made.

8x8 HDMI 2.0 HDBaseT Matrix Switcher

6.8 Network Setting

Switching	Audio	Configuration	CEC	RS232	Access	Interface	Network
-----------	-------	---------------	-----	-------	--------	-----------	---------

MAC Address: 44-33-4C-C9-35-12

DHCP Static IP

IP Address:

Subnet Mask:

Gateway:

- Static IP or Dynamic Host Configuration Protocol (DHCP).
- Modify the static IP Address, Subnet Mask, and Gateway.

8x8 HDMI 2.0 HDBaseT Matrix Switcher

6.9 GUI Upgrade

Please visit at <http://192.168.0.178:100> for GUI online upgrade.

Type the username and password (the same as the GUI log-in setting, modified password will be available only after rebooting) to login the configuration interface. After that, click **Administration** in the source menu to get to **Upload Firmware** as shown below:

The screenshot shows the WEB SERVER interface. The left sidebar contains a tree view of the configuration menu, with 'Administration' expanded and 'Upload Firmware' highlighted by a red circle. The main content area is titled 'Upgrade Firmware' and contains a warning message: 'Upgrade the MediaTek SoC firmware to obtain new functionality. It takes about 1 minute to upload & upgrade flash and be patient please. Caution! A corrupted image will hang up the system.' Below the warning is a form with a 'Location:' label, a 'Choose File' button, and an 'Apply' button.

Select the update file and click **Apply** button, and then it will start upgrade process.

8x8 HDMI 2.0 HDBaseT Matrix Switcher

7. IR Control

7.1 IR Remote Control

The matrix switcher has a built-in IR sensor on the front panel for receiving IR control signal from IR remote. In addition, it also provides IR EYE port on the rear panel to connect an external IR receiver for IR local control.

The matrix switcher can be controlled by the below IR Remote:

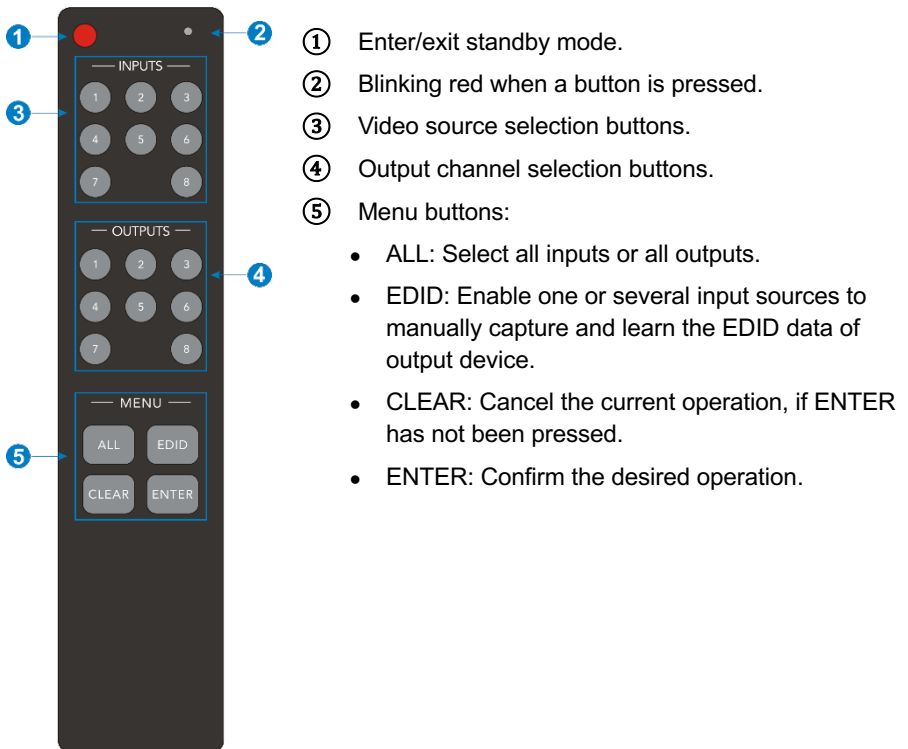

Note: The IR receivers which are connected to HDBaseT receivers also can receive the IR signal of the IR remote, so the matrix switcher also can be controlled by the IR remote at the far-end HDBaseT receivers' position. The IR remote-control mode can be enabled or disabled by sending RS232 command "IRRCM[XX]ON. "/ "IRRCM[xx]OFF." ([xx]=00~04). Please refer to the [8.3.1 System Control](#) for more details.

7.2 IR Pass-through Control

8x8 HDMI 2.0 HDBaseT Matrix Switcher

The matrix switcher supports bi-directional IR pass-through, allowing the devices can be controlled by both source and destination ends. This section provides connection and switching examples to illustrate possible configurations.

7.2.1 Control Local Input Device from Remote

The same basic principle applies when controlling the local input device from the remote location.

- **Control local input device through IR OUT port**

Example: Switch HDMI input 3 to HDBaseT output 4.

Connect an IR receiver to **IR IN** port on the receiver, then connect an IR emitter to the **IR OUT 3** on the matrix switcher. The third input source can be controlled through its corresponding IR output port. The connection diagram shown as below:

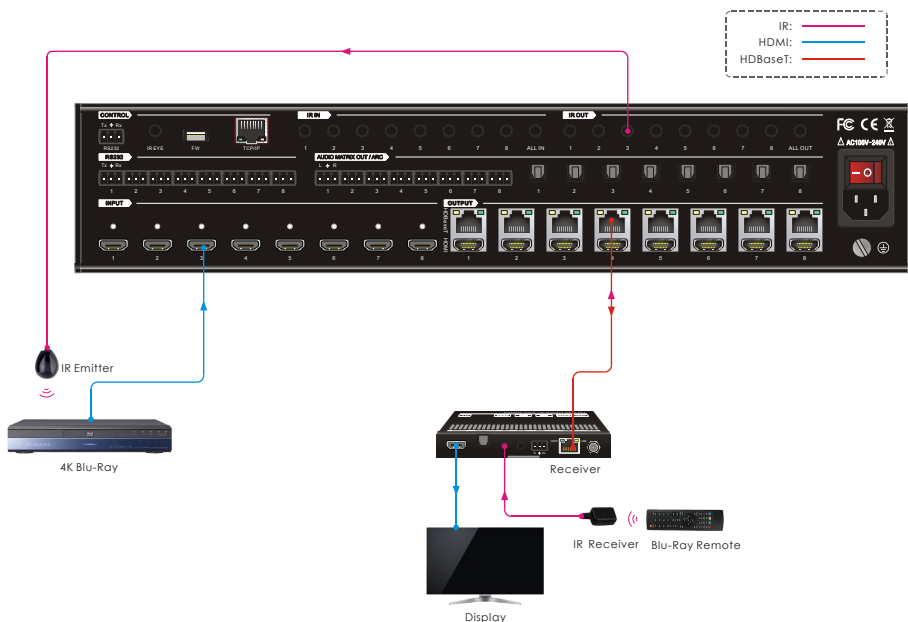

8x8 HDMI 2.0 HDBaseT Matrix Switcher

- Control local input device through IR ALL OUT port

The emitter can be connected to the **IR ALL OUT** port on matrix switcher to control all local input devices. In this case, the IR receiver must be connected to the **IR IN** port on each connected HDBaseT receiver, as shown in the diagram below:

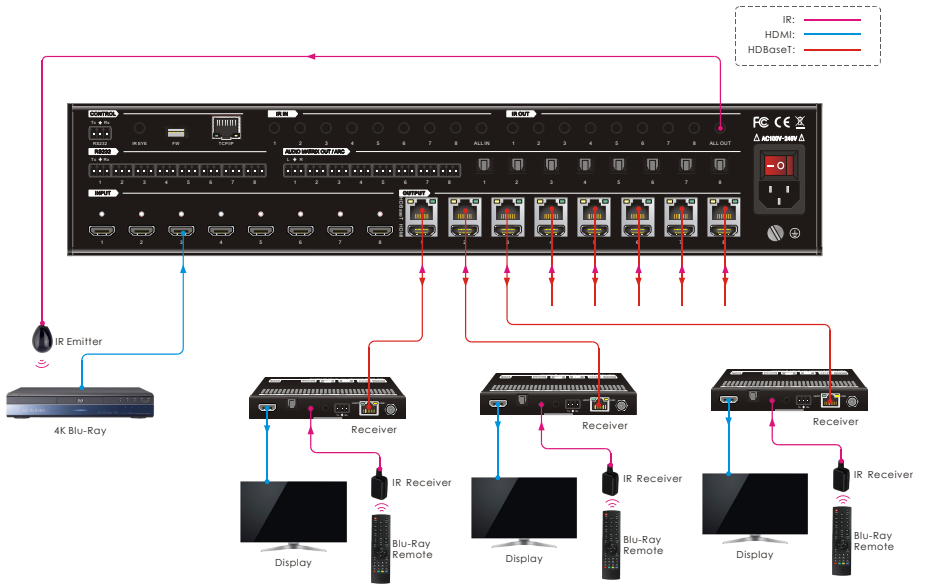

8x8 HDMI 2.0 HDBaseT Matrix Switcher

7.2.2 Control Remote Output Device from Local

The remote displays can be controlled from the local matrix switcher location.

- **Control remote device through IR IN port**

Example: Switch HDMI input 3 to HDBaseT output 3.

Connect an IR receiver to **IR IN 3** port on the matrix switcher, then connect an IR emitter to the **IR OUT** on the receiver, as shown in the diagram below:

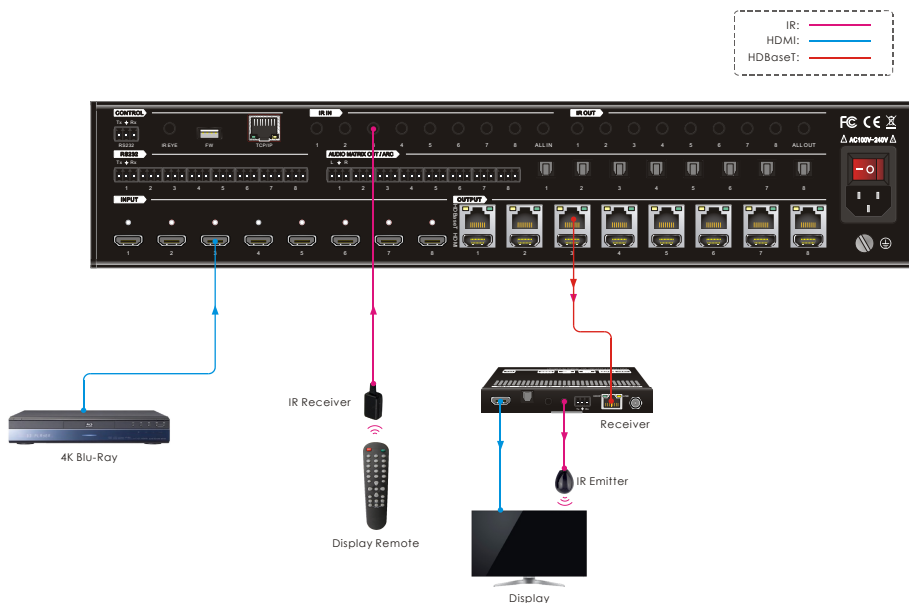

8x8 HDMI 2.0 HDBaseT Matrix Switcher

- Control remote device through IR ALL IN port

The receiver can be connected to the **IR ALL IN** port on matrix switcher to control all remote output devices. In this case, the IR emitter must be connected to the **IR OUT** port on each connected HDBaseT receiver, as shown in the diagram below:

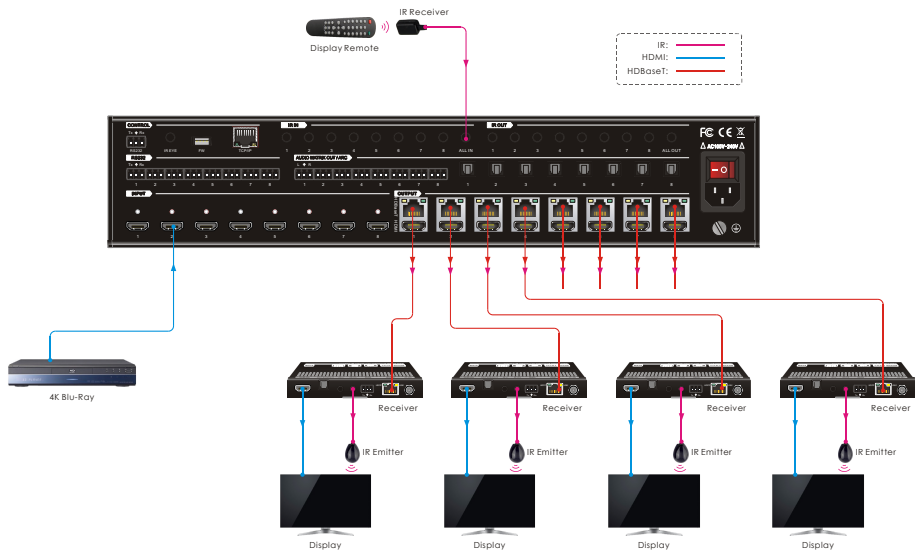

8x8 HDMI 2.0 HDBaseT Matrix Switcher

8. RS232 Control

8.1 RS232 Control Connection

8.1.1 Control the Matrix Switcher from Local

To control the matrix switcher from a local PC, the **3-pin to DB9 RS232 Cable** is used to connect between the matrix and PC. The connection diagram is shown as below:

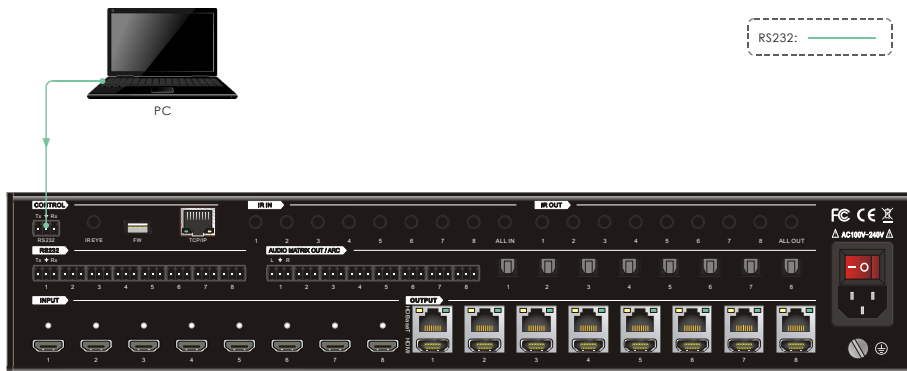

8x8 HDMI 2.0 HDBaseT Matrix Switcher

8.1.2 Control the Matrix Switcher from Remote

To control the matrix switcher from remote location, please connect one or more PCs to the **RS232** ports of HDBaseT receivers with the **3-pin to DB9 RS232 Cables**. The matrix switcher can be controlled by any one of PCs, the connection diagram is shown as below:

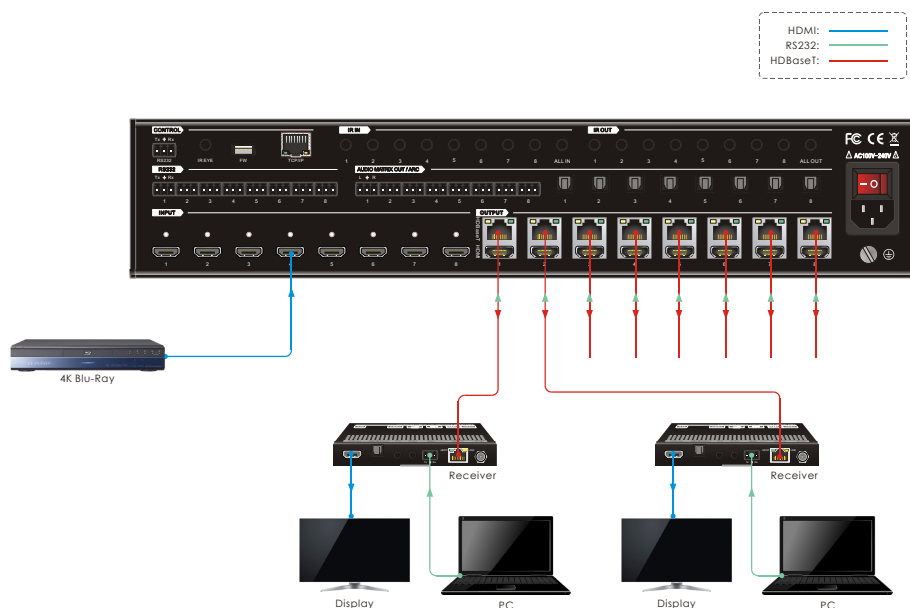

Note: The command **"RS232RCM[xx]ON."** (**[xx]=00~04**) needs to be sent to enable or disable this control mode. For example, send the command **"RS232RCM00ON."** to enable the remote-control mode for all HDBaseT outputs, and send the command **"RS232RCM00OFF."** to disable the remote-control mode for all HDBaseT outputs. Please refer to the [8.3.1 System Control](#) for more details.

8x8 HDMI 2.0 HDBaseT Matrix Switcher

8.1.3 Control the Remote Third-party Device from Local

To control a third-party device from local, first determine which HDBaseT receiver is connected to (1 in the diagram below). Next, connect a PC to the corresponding **RS232** port of matrix switcher with **3-pin to DB9 RS232 Cable**, then connect a third-party device (e.g. projector) to the **RS232** port of the determined HDBaseT receiver. The remote third-party device can be controlled by the local PC, the connection diagram is shown as below:

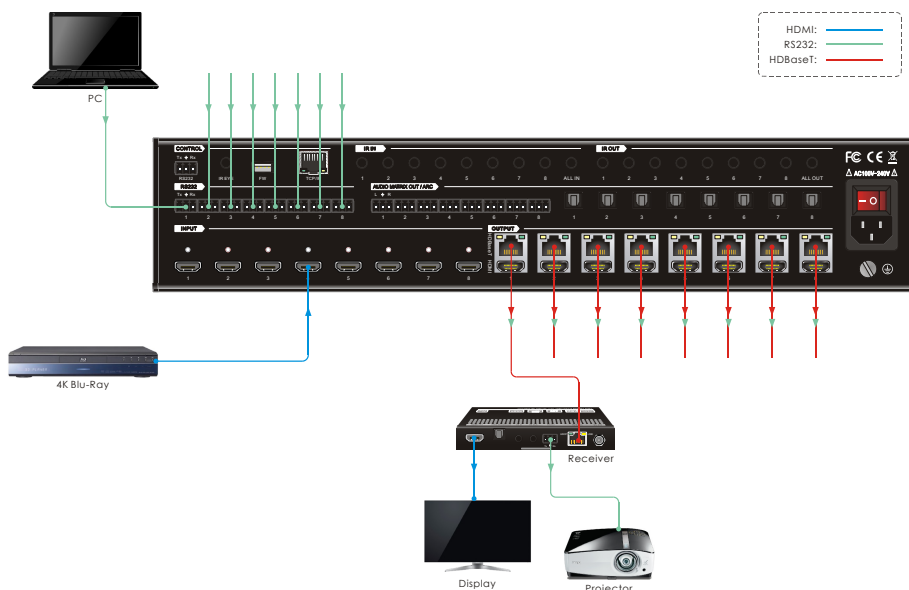

8x8 HDMI 2.0 HDBaseT Matrix Switcher

8.1.4 Control the Local Third-party Device from Remote

To control a third-party device from remote, first determine which HDBaseT receiver is connected to (1 in the diagram below). Next, connect a PC to the **RS232** port of HDBaseT receiver with **3-pin to DB9 RS232 Cable**, then connect a third-party device (e.g. projector) to the **RS232** port of matrix switcher. The local third-party device can be controlled by the remote PC, the connection diagram is shown as below:

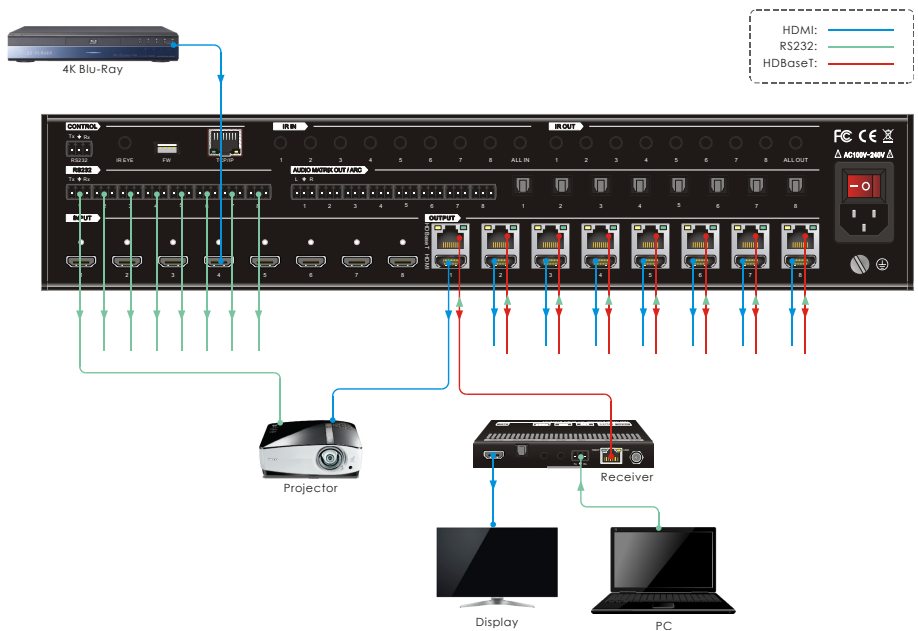

8x8 HDMI 2.0 HDBaseT Matrix Switcher

8.2 RS232 Control Software

If the matrix switcher and third-party devices needs to be controlled from PC by an RS232 connection, a RS232 control software should be installed in PC. Here using **CommWatch.exe** as an example. The icon is shown as below:



Double-click the icon to run, and its interface is depicted below:

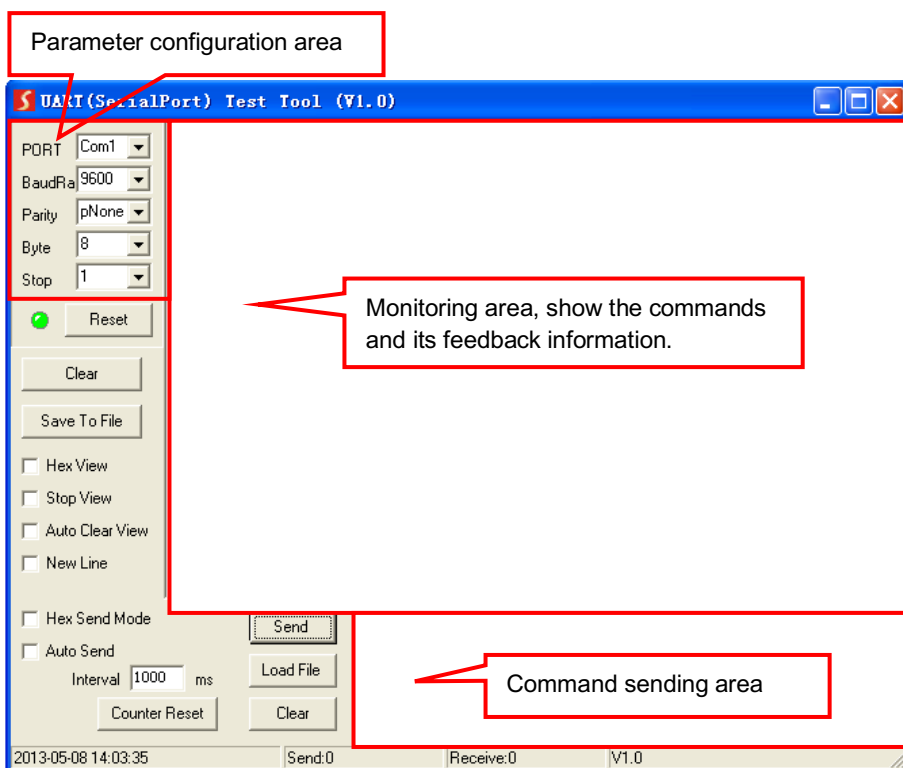

Please set the parameters of COM number, bound rate, data bit, stop bit and the parity bit correctly, and then you are able to send command in command sending area.

8x8 HDMI 2.0 HDBaseT Matrix Switcher

8.3 RS232 Commands

When controlling the matrix, the serial port settings for all RS232 commands is:

Baud rate: 9600 Data bit: 8 Stop bit: 1 Parity bit: none

The matrix switcher can be controlled by sending the following RS232 commands:

8.3.1 System Setting

Command	Description	Command Example and Feedback
PowerON.	Power on the system.	Power ON!
PowerOFF.	Power off the system.	Power OFF!
/*Name.	Report product name.	MUH88T-H2
/*Type.	Report product model.	HDBaseT Matrix
/^Version.	Report software version.	V1.0.0 CPLD:V1.0.0 VideoDriverVersion:V1.0.0
RST.	Reset to factory default.	Factory Default!
Lock.	Lock front panel buttons.	Front Panel Locked!
Unlock.	Unlock front panel buttons.	Front Panel UnLock!
GetGuiIP.	Report the GUI IP.	GUI_IP:192.168.0.178!
SetGuiIP:xxx.xxx.xx x.xxx.	Set the GUI IP to xxx.xxx.xxx.xxx.	SetGuiIP:192.168.0.176. SetGuiIP:192.168.0.176!
Baudrate115200.	Set the serial baud rate of matrix switcher to 115200.	Set Local RS232 Baudrate Is 115200!
Baudrate57600.	Set the serial baud rate of matrix switcher to 57600.	Set Local RS232 Baudrate Is 57600!
Baudrate38400.	Set the serial baud rate of matrix switcher to 38400.	Set Local RS232 Baudrate Is 38400!
Baudrate19200.	Set the serial baud rate of matrix switcher to 19200	Set Local RS232 Baudrate Is 19200!
Baudrate9600.	Set the serial baud rate of matrix switcher to 9600.	Set Local RS232 Baudrate Is 9600!
PHDBTON.	Enable PoC of HDBT outputs for powering HDBaseT receivers.	HDBT Power ON!
PHDBTOFF.	Disable PoC of HDBT outputs.	HDBT Power OFF!
STA_PHDBT.	Report the PoC status of HDBT outputs.	HDBT Power ON!
DS[XX]ON.		DS00ON.

8x8 HDMI 2.0 HDBaseT Matrix Switcher

Command	Description	Command Example and Feedback
	<p>Enable the video resolution down-scaling function of HDMI output [XX]. [XX]=00~08. The "[XX]=00" represents all HDMI outputs.</p>	<p>HDMI OUT 01 Down Scale ON! HDMI OUT 02 Down Scale ON! HDMI OUT 08 Down Scale ON!</p>
DS[XX]OFF.	<p>Disable the video resolution down-scaling function of HDMI output [XX]. [XX]=00~08. The "[XX]=00" represents all HDMI outputs.</p>	<p>DS00OFF. HDMI OUT 01 Down Scale OFF! HDMI OUT 08 Down Scale OFF!</p>
STA_DS.	<p>Report the down-scaling function of HDMI outputs.</p>	<p>HDMI OUT 01 Down Scale OFF! HDMI OUT 02 Down Scale OFF! HDMI OUT 08 Down Scale OFF!</p>
RS232RCM[XX]ON.	<p>Enable the RS232 remote-control mode for HDBT output [XX] that the matrix switcher can be controlled from remote PC. [XX]=00~08. The "[XX]=00" represents all HDBT outputs.</p>	<p>RS232RCM00ON. RS232 Remote 01 Control MCU ON! RS232 Remote 02 Control MCU ON! RS232 Remote 08 Control MCU ON!</p>
RS232RCM[XX]OFF.	<p>Disable the RS232 remote-control mode for HDBT output [XX] that the matrix switcher cannot be controlled from remote PC. [XX]=00~08. The "[XX]=00" represents all HDBT outputs.</p>	<p>RS232RCM00OFF. RS232 Remote 01 Control MCU OFF! RS232 Remote 02 Control MCU OFF! RS232 Remote 08 Control MCU OFF!</p>

8x8 HDMI 2.0 HDBaseT Matrix Switcher

Command	Description	Command Example and Feedback
STA_RS232RCM.	Report the RS232 remote-control mode status.	RS232 Remote 01 Control MCU OFF! RS232 Remote 02 Control MCU OFF! RS232 Remote 08 Control MCU OFF!
IRRCM[XX]ON.	Enable the IR remote-control mode for HDBT output [XX] that the matrix switcher can be controlled by the IR remote at the far-end HDBaseT receivers' position. [XX]=00~08. The "[XX]=00" represents all HDBT outputs.	IRRCM00ON. IR Remote 01 Control MCU ON! IR Remote 02 Control MCU ON! IR Remote 08 Control MCU ON!
IRRCM[XX]OFF.	Disable the IR remote-control mode for HDBT output [XX] that the matrix switcher cannot be controlled by the IR remote at the far-end HDBaseT receivers' position. [XX]=00~08. The "[XX]=00" represents all HDBT outputs.	IRRCM00OFF. IR Remote 01 Control MCU OFF! IR Remote 02 Control MCU OFF! IR Remote 08 Control MCU OFF!
STA_IRRCM.	Report the IR remote-control mode status.	IR Remote 01 Control MCU ON! IR Remote 02 Control MCU ON! IR Remote 08 Control MCU ON!
@OUT[XX].	Turn on output [XX]. [XX]=00~16. The "[XX]=00" represents all outputs. [XX]=01~08, represents HDBT output 1~8. [XX]=09~16, represents HDMI output 1~8.	@OUT00. Turn ON Output 01! Turn ON Output 02! Turn ON Output 16!
\$OUT[XX].		\$OUT00.

8x8 HDMI 2.0 HDBaseT Matrix Switcher

Command	Description	Command Example and Feedback
	Turn off output [XX]. [XX]=00~16. The "[XX]=00" represents all outputs. [XX]=01~08, represents HDBT output 1~8. [XX]=09~16, represents HDMI output 1~8.	Turn OFF Output 01! Turn OFF Output 02! Turn OFF Output 16!
STA_POUT.	Report the on/off status of all outputs.	Turn ON Output 01! Turn ON Output 02! Turn ON Output 16!
STA.	Report all system status.	GUI Or RS232 Query Status: HDBaseT Matrix MUH88T-H2 V1.0.0 Power ON! HDBT Power ON! Front Panel UnLock! Local RS232 Baudrate Is 9600! GUI_IP:192.168.0.178! Output 01 Switch To In 01!
STA_IN.	Report the connection status of all HDMI input ports.	IN 1 2 3 4 5 6 7 8 LINK N N N Y N Y N Y
STA_OUT.	Report the connection status of all HDMI and HDBT outputs.	OUT 1 2 3 4 5 6 7 8 9 10 11 12 13 14 15 16 LINK N N N Y N N N N N N N Y N N N N

8.3.2 Signal Switching

Command	Description	Command Example and Response
IRFVON.	Enable the IR switching to follow the video switching.	IR Follow Video ON!

8x8 HDMI 2.0 HDBaseT Matrix Switcher

Command	Description	Command Example and Response
IRFVOFF.	Disable the IR switching to follow the video switching.	IR Follow Video OFF!
OUT[XX]:[YY].	Switch video input [YY] to video output [XX]. [XX]=00~08, [YY]=01~08. The "[XX]=00" represents all outputs.	OUT01:04.
		Output 01 Switch To In 04!
STA_VIDEO.	Report the input channel for all outputs.	Output 01 Switch To In 01! Output 02 Switch To In 02! Output 03 Switch To In 03! Output 08 Switch To In 08!
IR[XX]:[YY].	Switch far-end IR IN [YY] to local IR OUT [XX]. [XX]=01~08, [YY]=00~08. The "[YY]=00" represents all far-end IR IN ports.	IR01:03.
		Local 01 IR Out Switch To Remote 03 IR IN!
STA_IR.	Report IR switching status.	IR Follow Video ON! Local 01 IR Out Switch To Remote 01 IR IN! Local 02 IR Out Switch To Remote 02 IR IN! Local 08 IR Out Switch To Remote 04 IR IN!
PresetSave[XX].	Store the current switching status to present [XX]. [XX]=01~09.	PresetSave01.
		Preset 01 Save Success! Preset 01 Sta: Out 01 In 01! Out 02 In 02! Out 08 In 08!
PresetRecall[XX].	Recall present [XX]. [XX]=01~09.	PresetRecall02.
		Preset 02 Recall: Output 01 Switch To In 02! Local 02 IR Out Switch To Remote 01 IR IN! Output 02 Switch To In 02! Local 02 IR Out Switch To Remote 02 IR IN! Output 03 Switch To In 02!

8x8 HDMI 2.0 HDBaseT Matrix Switcher

Command	Description	Command Example and Response
		Local 02 IR Out Switch To Remote 03 IR IN! Output 04 Switch To In 02! Local 02 IR Out Switch To Remote 04 IR IN!
PresetSta[XX].	Report the preset [XX]. [XX]=01~09.	PresetSta01. Preset 01 Sta: Out 01 In 01! Out 02 In 01! Out 03 In 01! Out 08 In 01!

8.3.3 Audio Setting

Command	Description	Command Example and Response																																								
SPDIF[XX]:[YY].	Select audio source [YY] for SPDIF audio output [XX]. [XX]=00~08, The "[XX]=00" represents all SPDIF audio outputs. [YY]=01~24.	SPDIF01:04.																																								
	<table border="1"> <thead> <tr> <th>[YY]</th> <th>Audio Source</th> <th>[YY]</th> <th>Audio Source</th> </tr> </thead> <tbody> <tr> <td>01</td> <td>In1 Breakout</td> <td>13</td> <td>Out5 Breakout</td> </tr> <tr> <td>02</td> <td>In2 Breakout</td> <td>14</td> <td>Out6 Breakout</td> </tr> <tr> <td>03</td> <td>In3 Breakout</td> <td>15</td> <td>Out7 Breakout</td> </tr> <tr> <td>04</td> <td>In4 Breakout</td> <td>16</td> <td>Out8 Breakout</td> </tr> <tr> <td>05</td> <td>In5 Breakout</td> <td>17</td> <td>Out1 ARC</td> </tr> <tr> <td>06</td> <td>In6 Breakout</td> <td>18</td> <td>Out2 ARC</td> </tr> <tr> <td>07</td> <td>In7 Breakout</td> <td>19</td> <td>Out3 ARC</td> </tr> <tr> <td>08</td> <td>In8 Breakout</td> <td>20</td> <td>Out4 ARC</td> </tr> <tr> <td>09</td> <td>Out1 Breakout</td> <td>21</td> <td>Out5 ARC</td> </tr> </tbody> </table>	[YY]	Audio Source	[YY]	Audio Source	01	In1 Breakout	13	Out5 Breakout	02	In2 Breakout	14	Out6 Breakout	03	In3 Breakout	15	Out7 Breakout	04	In4 Breakout	16	Out8 Breakout	05	In5 Breakout	17	Out1 ARC	06	In6 Breakout	18	Out2 ARC	07	In7 Breakout	19	Out3 ARC	08	In8 Breakout	20	Out4 ARC	09	Out1 Breakout	21	Out5 ARC	SPDIF Out 01 Switch To Video In 04!
	[YY]	Audio Source	[YY]	Audio Source																																						
	01	In1 Breakout	13	Out5 Breakout																																						
	02	In2 Breakout	14	Out6 Breakout																																						
	03	In3 Breakout	15	Out7 Breakout																																						
	04	In4 Breakout	16	Out8 Breakout																																						
	05	In5 Breakout	17	Out1 ARC																																						
	06	In6 Breakout	18	Out2 ARC																																						
	07	In7 Breakout	19	Out3 ARC																																						
	08	In8 Breakout	20	Out4 ARC																																						
09	Out1 Breakout	21	Out5 ARC																																							

8x8 HDMI 2.0 HDBaseT Matrix Switcher

Command	Description				Command Example and Response
	10	Out2 Breakout	22	Out6 ARC	
	11	Out3 Breakout	23	Out7 ARC	
	12	Out4 Breakout	24	Out8 ARC	
STA_SPDIF.	Report SPDIF audio status.				SPDIF Out 01 Switch To Video In 01! SPDIF Out 02 Switch To Video In 02! SPDIF Out 08 Switch To Video In 08!
AVOLUME[XX]:[YY].	Set the volume of analog L+R audio output [XX] to [YY]. [XX]=00~08, The "[XX]=00" represents all L+R audio outputs.				AVOLUME00:V+. AVOLUME00:V-. AVOLUME01:MU. AVOLUME01:UM. AVOLUME01:05. AVOLUME01:100.
	[YY]	Description			Analog Out 01 Volume 61! Analog Out 08 Volume 61! Analog Out 01 Volume Mute! Analog Out 08 Volume Mute!
	V+	Volume Up			
	V-	Volume down			
	MU	Mute			
	UM	Unmute			
	00~100	Volume value			

8x8 HDMI 2.0 HDBaseT Matrix Switcher

Command	Description	Command Example and Response																																				
		Analog Out 01 Volume UnMute! Analog Out 08 Volume UnMute!																																				
<p>ANALOG[XX]:[YY].</p>	<p>Select audio source [YY] for analog L+R audio output [XX]. [XX]=00~08, The "[XX]=00" represents all L+R audio outputs. [YY]=01~16.</p> <table border="1" data-bbox="350 539 758 1129"> <thead> <tr> <th>[YY]</th> <th>Audio Source</th> <th>[YY]</th> <th>Audio Source</th> </tr> </thead> <tbody> <tr> <td>01</td> <td>In1 Breakout</td> <td>09</td> <td>Out1 Breakout</td> </tr> <tr> <td>02</td> <td>In2 Breakout</td> <td>10</td> <td>Out2 Breakout</td> </tr> <tr> <td>03</td> <td>In3 Breakout</td> <td>11</td> <td>Out3 Breakout</td> </tr> <tr> <td>04</td> <td>In4 Breakout</td> <td>12</td> <td>Out4 Breakout</td> </tr> <tr> <td>05</td> <td>In5 Breakout</td> <td>13</td> <td>Out5 Breakout</td> </tr> <tr> <td>06</td> <td>In6 Breakout</td> <td>14</td> <td>Out6 Breakout</td> </tr> <tr> <td>07</td> <td>In7 Breakout</td> <td>15</td> <td>Out7 Breakout</td> </tr> <tr> <td>08</td> <td>In8 Breakout</td> <td>16</td> <td>Out8 Breakout</td> </tr> </tbody> </table>	[YY]	Audio Source	[YY]	Audio Source	01	In1 Breakout	09	Out1 Breakout	02	In2 Breakout	10	Out2 Breakout	03	In3 Breakout	11	Out3 Breakout	04	In4 Breakout	12	Out4 Breakout	05	In5 Breakout	13	Out5 Breakout	06	In6 Breakout	14	Out6 Breakout	07	In7 Breakout	15	Out7 Breakout	08	In8 Breakout	16	Out8 Breakout	<p>ANALOG01:04.</p> <p>Analog Out 01 Switch To Video In 04!</p>
[YY]	Audio Source	[YY]	Audio Source																																			
01	In1 Breakout	09	Out1 Breakout																																			
02	In2 Breakout	10	Out2 Breakout																																			
03	In3 Breakout	11	Out3 Breakout																																			
04	In4 Breakout	12	Out4 Breakout																																			
05	In5 Breakout	13	Out5 Breakout																																			
06	In6 Breakout	14	Out6 Breakout																																			
07	In7 Breakout	15	Out7 Breakout																																			
08	In8 Breakout	16	Out8 Breakout																																			
<p>STA_ANALOG.</p>	<p>Report analog L+R audio status.</p>	<p>Analog Out Volume UnMute! Analog Out Volume 76! Analog Out 01 Switch To Video In 04! Analog Out 02 Switch To Video Out 02! Analog Out 08 Switch To Video Out 08!</p>																																				

8x8 HDMI 2.0 HDBaseT Matrix Switcher

8.3.4 HDCP Setting

Command	Description	Command Example and Response
HDCP[XX]MAT.	<p>The HDCP content of output [XX] follows the HDCP version of display device.</p> <p>[XX]=00~16.</p> <p>[XX]=00, represents all outputs.</p> <p>[XX]=01~08, represents HDBT output 1~8.</p> <p>[XX]=09~16, represents HDMI output 1~8.</p>	HDCP00MAT.
		<p>OUT 01 HDCP MAT Display!</p> <p>... ..</p> <p>OUT 15 HDCP MAT Display!</p> <p>OUT 16 HDCP MAT Display!</p>
HDCP[XX]PAS.	<p>Set the HDCP mode of output [XX] to Passive.</p> <p>The HDCP content of output [XX] automatically follows the HDCP version of source device.</p> <p>[XX]=00~16.</p> <p>[XX]=00, represents all outputs.</p> <p>[XX]=01~08, represents HDBT output 1~8.</p> <p>[XX]=09~16, represents HDMI output 1~8.</p>	HDCP00pAS.
		<p>OUT 01 HDCP PASSIVE!</p> <p>OUT 02 HDCP PASSIVE!</p> <p>... ..</p> <p>OUT 15 HDCP PASSIVE!</p> <p>OUT 16 HDCP PASSIVE!</p>
HDCP[XX]BYP.	<p>Set the HDCP mode of output [XX] to Active.</p> <p>If the input video has HDCP content, the HDCP version of HDMI output is HDCP 1.4 for broader video solution. If the input video has no HDCP content, the HDMI output has no HDCP too.</p> <p>[XX]=00~16.</p> <p>[XX]=00, represents all outputs.</p> <p>[XX]=01~08, represents HDBT output 1~8.</p> <p>[XX]=09~16, represents HDMI output 1~8.</p>	HDCP00BYP.
		<p>OUT 01 HDCP BYPASSSS!</p> <p>OUT 02 HDCP BYPASSSS!</p> <p>... ..</p> <p>OUT 15 HDCP BYPASSSS!</p> <p>OUT 16 HDCP BYPASSSS!</p>
STA_HDCP.	Report the HDCP mode of all outputs.	<p>OUT 01 HDCP BYPASSSS!</p> <p>OUT 02 HDCP BYPASSSS!</p> <p>... ..</p> <p>OUT 15 HDCP BYPASSSS!</p> <p>OUT 16 HDCP BYPASSSS!</p>

8x8 HDMI 2.0 HDBaseT Matrix Switcher

8.3.5 EDID Management

Command	Description	Command Example and Response																
EDIDInit.	Reset factory default EDID to all input ports.	All Input EDID Set Default!																
EDIDUpgrade[XX].	Upgrade the EDID data of the input port [XX]. [XX]=00~08, U. [XX]=00, represents all inputs. [XX]=01~08, represents HDMI input 1~8. [XX]=U, upload a user-defined EDID. The EDID can be saved for invoking at any time. When the command applied, system prompts to upload the EDID file (.bin). Operation will be cancelled in 10 seconds. Please disconnect HDBT connection before sending command to ensure the data can be received successfully.	EDIDUpgrade01.																
		EDIDUpgradeU. 256 9600bps Input XX/User Define EDID Upgrade OK By RS232 Or GUI!																
EDID/[XX]/[YY].	The input [XX] recall the embedded EDID [YY]. [XX]=00~08. The "00" represents all inputs. [YY]=01~07.	EDID/03/01.																
	<table border="1"> <thead> <tr> <th>[YY]</th> <th>EDID</th> </tr> </thead> <tbody> <tr> <td>01</td> <td>1080p 2CH</td> </tr> <tr> <td>02</td> <td>1080p MultiCH</td> </tr> <tr> <td>03</td> <td>4K@30Hz HDR 2CH</td> </tr> <tr> <td>04</td> <td>4K@30Hz HDR MultiCH</td> </tr> <tr> <td>05</td> <td>4K@60Hz HDR 2CH</td> </tr> <tr> <td>06</td> <td>4K@60Hz HDR MultiCH</td> </tr> <tr> <td>07</td> <td>User-defined EDID</td> </tr> </tbody> </table>	[YY]	EDID	01	1080p 2CH	02	1080p MultiCH	03	4K@30Hz HDR 2CH	04	4K@30Hz HDR MultiCH	05	4K@60Hz HDR 2CH	06	4K@60Hz HDR MultiCH	07	User-defined EDID	Input 03 EDID Upgrade OK By 01 Internal EDID!
	[YY]	EDID																
	01	1080p 2CH																
	02	1080p MultiCH																
	03	4K@30Hz HDR 2CH																
	04	4K@30Hz HDR MultiCH																
	05	4K@60Hz HDR 2CH																
06	4K@60Hz HDR MultiCH																	
07	User-defined EDID																	
EDIDGOUT[XX].	Report the EDID data from output [XX]. [XX]=01~16. [XX]=01~08, represents HDBT output 1~8. [XX]=09~16, represents HDMI output 1~8.	EDIDGOUT04. EDIDOUT04:																
EDIDM[XX]B[YY].	Copy the EDID data of output [XX] to input [YY]. [XX]=01~16, YY=00~08. [XX]=01~08, represents HDBT output 1~8. [XX]=09~16, represents HDMI output 1~8.	EDIDM04B01.																
		Input 01 EDID Upgrade OK By 04 EXT EDID!																

8x8 HDMI 2.0 HDBaseT Matrix Switcher

Command	Description	Command Example and Response
	[YY]=00, represents all inputs. [YY]=01~08, represents HDMI input 1~8.	
EDIDSTA[XX].	Report the EDID status of input [XX]. [XX]=00~08. [XX]=00, represents all inputs. [XX]=01~08, represents HDMI input 1~8.	EDIDSTA00. Input 01 EDID From 01 Internal EDID! Input 02 EDID From 01 Internal EDID! Input 07 EDID From 01 Internal EDID! Input 08 EDID From 01 Internal EDID!

8.3.6 Third-party Device Control

Command	Description	Command Example
/+ [X]/[YY]:xxx.	Send the ASCII command "xxx" to control the far-end third-party device. <ul style="list-style-type: none"> • xxx: ASCII string. • The "[X]=1~7" represents the baud rate of third-party device. [X]=1, the baud rate is 2400 [X]=2, the baud rate is 4800 [X]=3, the baud rate is 9600 [X]=4, the baud rate is 19200 [X]=5, the baud rate is 38400 [X]=6, the baud rate is 57600 [X]=7, the baud rate is 115200 • The "[YY]=00" represents all HDBT outputs. • The "[YY]=01~08" represents the HDBT output 1~8. 	/+3/01:123456. Send the ASCII command "123456." to the far-end third-party device whose baud rate is 9600. The third-party device is connected to the far-end HDBaseT receiver of connecting the HDBT output 1 port.
	When power on the matrix switcher, automatically send ASCII command "xxx" to power on far-end third-party device. <ul style="list-style-type: none"> • xxx: ASCII string. 	CMDON/+3/01:123456. When power on the matrix switcher, automatically send ASCII command

8x8 HDMI 2.0 HDBaseT Matrix Switcher

	<ul style="list-style-type: none"> • The "[X]=1~7" represents the baud rate of third-party device. [X]=1, the baud rate is 2400 [X]=2, the baud rate is 4800 [X]=3, the baud rate is 9600 [X]=4, the baud rate is 19200 [X]=5, the baud rate is 38400 [X]=6, the baud rate is 57600 [X]=7, the baud rate is 115200 • The "[YY]=00" represents all HDBT outputs. • The "[YY]=01~08" represents the HDBT output 1~8. 	<p>"123456" to the far-end third-party device. The third-party device is connected to the far-end HDBaseT receiver of connecting the HDBT output 1 port.</p>
<p>CMDOFF/+[X]/[YY]: xxx.</p>	<p>When power off the matrix switcher, automatically send ASCII command "xxx" to power off far-end third-party device.</p> <ul style="list-style-type: none"> • xxx: ASCII string. • The "[X]=1~7" represents the baud rate of third-party device. [X]=1, the baud rate is 2400 [X]=2, the baud rate is 4800 [X]=3, the baud rate is 9600 [X]=4, the baud rate is 19200 [X]=5, the baud rate is 38400 [X]=6, the baud rate is 57600 [X]=7, the baud rate is 115200 • The "[YY]=00" represents all HDBT outputs. • The "[YY]=01~08" represents the HDBT output 1~8. 	<p>CMDOFF/+3/01:123456.</p> <p>When power off the matrix switcher, automatically send ASCII command "123456" to the far-end third-party device. The third-party device is connected to the far-end HDBaseT receiver of connecting the HDBT output 1 port.</p>

8.3.7 CEC Control

If the input sources, HDBaseT output devices and local HDMI output devices are supports CEC, they can be controlled by sending the following command instead of IR remote.

CEC[I]/[O][AA][BB][CC][DD].

- The "[I]" represents the input port. The "[O]" represents the output port.
- The "[AA]" represents the port number. The HDMI input ports are 01~08. The

8x8 HDMI 2.0 HDBaseT Matrix Switcher

HDBaseT output ports are 01~08 and the local HDMI output ports are 09~16.

- The “[AA]” is “FF” for sending command to all input or output ports.
- The “[BB]” represents the device type (e.g. TV: 40/20/80; Blu-ray DVD: 04/08).
- The “[CC]” represents the function type (e.g. “44”: Remote control).
- The “[DD]” represents the specific command from the table below.

8x8 HDMI 2.0 HDBaseT Matrix Switcher

✓ **Control the input source:**

Command	Description	Command Example and Response
CECI[AA][BB][CC]00.	Confirm operation (Enter).	CECI02044400
		CEC Input 02 Send Success!
CECI[AA][BB][CC]01.	UP direction.	CECI01044401.
		CEC Input 01 Send Success!
CECI[AA][BB][CC]02.	DOWN direction.	CECI01044402.
		CEC Input 01 Send Success!
CECI[AA][BB][CC]03.	LEFT direction.	CECI03044403.
		CEC Input 03 Send Success!
CECI[AA][BB][CC]04.	RIGHT direction.	CECI03044404.
		CEC Input 03 Send Success!
CECI[AA][BB][CC]09.	Back to submenu.	CECI03044409.
		CEC Input 03 Send Success!
CECI[AA][BB][CC]0A.	Enter main menu.	CECI0304440A.
		CEC Input 03 Send Success!
CECI[AA][BB][CC]0D.	Exit menu.	CECI0204440D.
		CEC Input 02 Send Success!
CECI[AA][BB][CC]6D.	Power on.	CECI0204446D.
		CEC Input 02 Send Success!
CECI[AA][BB][CC]6C.	Power off.	CECI0204446C.
		CEC Input 02 Send Success!

✓ **Control the output display device:**

Command	Description	Command Example and Response
CECO[AA][BB][CC]41.	Volume up.	CECO05404441.
		CEC Output 05 Send Success!
CECO[AA][BB][CC]42.	Volume down.	CECO05404442.
		CEC Output 05 Send Success!
CECO[AA][BB][CC]43.	Mute	CECO05404443.
		CEC Output 05 Send Success!
CECO[AA][BB]04.	Power on.	CECO038004.
		CEC Output 03 Send Success!
CECO[AA][BB]36.	Power off.	CECO038036.
		CEC Output 03 Send Success!

9. Firmware Upgrade

Please follow the steps as below to upgrade firmware by the **FW** port on the rear panel:

- 1) Prepare the latest two upgrade files and rename them as "08010000.APP" and "08010000.APS" on PC.
- 2) Power off the switcher, and connect the **FW** port of switcher to the PC with USB cable.
- 3) Power on the switcher, and then the PC will automatically detect a U-disk named of "BOOTDISK".
- 4) Double-click the U-disk, a file named of "READY.TXT" would be showed.
- 5) Directly copy one of two upgrade files (e.g. "08010000.APP") to the "BOOTDISK" U-disk.
- 6) Reopen the U-disk to check the filename "READY.TXT" whether automatically becomes "SUCCESS.TXT", if yes, the firmware was updated successfully, otherwise, the firmware updating is fail, the name of upgrade file should be confirm again, and then follow the above steps to update again.
- 7) Repeat step 5~6 to copy the other upgrade file ("08010000.APS") to the "BOOTDISK" U-disk.
- 8) Remove the USB cable after firmware upgrade.
- 9) After firmware upgrade, the switcher should be restored to factory default by sending command.

8x8 HDMI 2.0 HDBaseT Matrix Switcher

10. Panel Drawing

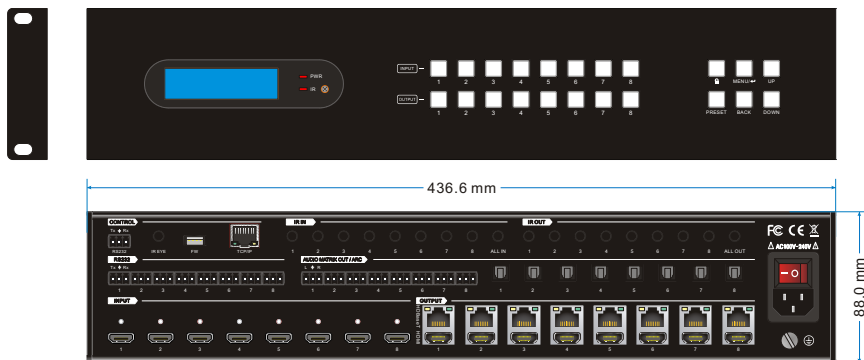

MUH88T-H2 Matrix Switcher

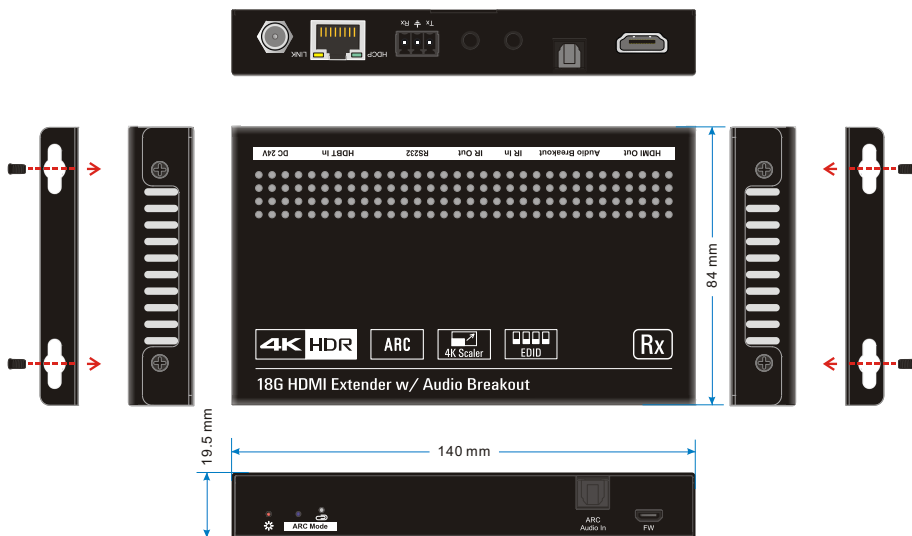

TPUH610SR HDBaseT Receiver

8x8 HDMI 2.0 HDBaseT Matrix Switcher

11. Troubleshooting & Maintenance

Problems	Potential Causes	Solutions
Output image with snowflake.	Bad quality of the connecting cable.	Try another high-quality cable.
	Fail or loose connection.	Make sure the connection is good.
No output image when switching.	No signal at the input / output end.	Check with oscilloscope or multimeter if there is any signal at the input/ output end.
	Fail or loose connection.	Make sure the connection is good.
	The product is broken.	Send it to authorized dealer for repairing.
POWER indicator doesn't work or no respond to any operation.	Fail connection of power cord.	Make sure the power cord connection is good.
EDID management does not work normally.	The HDMI cable is broken at the output end.	Change for another HDMI cable which is in good working condition.
Static becomes stronger when connecting the video connectors.	Bad grounding.	Check the grounding and make sure it is connected well.
Cannot control the device by control device (e.g. a PC) through RS232 port.	Wrong RS232 communication parameters.	Type in correct RS232 communication parameters.
	Broken RS232 port.	Send it to authorized dealer for checking.
Cannot control the device by front panel buttons while can control it through RS232 port	The front panel buttons are locked.	Send command !%Unlock; to unlock the front panel buttons.

Note: If your problem still remaining after following the above troubleshooting steps, please contact your local dealer or distributor for further assistance.

12. Customer Service

The return of a product to our Customer Service implies the full agreement of the terms and conditions hereinafter. These terms and conditions may be changed without prior notice.

1) Warranty

The limited warranty period of the product is fixed three years.

2) Scope

These terms and conditions of Customer Service apply to the customer service provided for the products or any other items sold by authorized distributor only.

3) Warranty Exclusion

- Warranty expiration.
- Factory applied serial number has been altered or removed from the product.
- Damage, deterioration or malfunction caused by:
 - ✓ Normal wear and tear.
 - ✓ Use of supplies or parts not meeting our specifications.
 - ✓ No certificate or invoice as the proof of warranty.
 - ✓ The product model showed on the warranty card does not match with the model of the product for repairing or had been altered.
 - ✓ Damage caused by force majeure.
 - ✓ Servicing not authorized by distributor.
 - ✓ Any other causes which does not relate to a product defect.
- Shipping fees, installation or labor charges for installation or setup of the product.

4) Documentation

Customer Service will accept defective product(s) in the scope of warranty coverage at the sole condition that the defeat has been clearly defined, and upon reception of the documents or copy of invoice, indicating the date of purchase, the type of product, the serial number, and the name of distributor.

Remarks: Please contact your local distributor for further assistance or solutions.